



Tamil Nadu Road Development Company Ltd. (TNRDC)

Construction of Road adjacent to IOCL (L&G) Regasification Terminal Road (inside the KPL) Km:0/000 to Km:2/410

BID DOCUMENT

| | |
|---------------|-------------------------------------|
| Section I : | Instruction to Bidders |
| Section II : | Forms of Bids & Forms of Securities |
| Section III : | Conditions of Contract |
| Section IV : | Contract Data |
| Section V : | Bill of Quantities |
| Section VI : | Drawings |
| Section VII : | Technical Specifications |

TNRDC

Tamil Nadu Road Development Company Limited,
No.171, II Floor, Tamil Nadu Maritime Board Building,
South Kesavaperumal Puram,
Pasumpon Muthuramalingam Road,
(Near Greenways Road MRTS Station),
Raja Annamalai Puram, Chennai 600 028
Phone: 91-44-2495 2800 / 3800,
Fax: 91-44-2493 3800
E-Mail: tenders@tnrdc.com
Web : www.tnrdc.com

Tamil Nadu Road Development Company Ltd.

(TNRDC)

Construction of Road adjacent to IOCL (L&G) Regasification Terminal Road
(inside the KPL) Km:0/000 to Km:2/410

Schedule of Bidding Process

| | |
|--|--|
| Period of Issue of Tender Document | 22nd October, 2020 to 24th November, 2020 |
| Bid Document Price(inclusive of GST) | Rs 28,000/- DD in Favour of M/s. Tamil Nadu Road Development Company Limited (TNRDC), payable at Chennai |
| Last Date and Time for Receipt of Bids | 25th November, 2020 at 15.00 Hrs |
| Pre-Bid Meeting | 06th November, 2020 at 15:00 Hrs |
| Bid – Opening Date and Time: Technical Bid Opening Financial Bid Opening | 25th November, 2020 at 15.30 Hrs Date will be intimated to the Technically Qualified bidders later |

Tamil Nadu Road Development Company Ltd.(TNRDC)

**Construction of Road adjacent to IOCL (L&G) Regasification
Terminal Road (inside the KPL) Km:0/000 to Km:2/410**

CONTENTS of BID DOCUMENTS

| Invitation for Bids | |
|----------------------------|------------------------------------|
| Section I | Instruction to Bidders |
| Section II | Forms of Bid & Forms of Securities |
| Section III | Conditions of Contract |
| Section IV | Contract Data |
| Section V | Bill of Quantities (BoQ) |
| Section VI | Drawings |
| Section VII | Technical Specifications |



Tamil Nadu Road Development Company Ltd.

INVITATION FOR BIDS

Tender Notice No.:TNRDC/CD/019/2020

Date: 19.10.2020

Bids are invited by **M/s.Tamil Nadu Road Development Company Ltd. (TNRDC)** for implementation of the following work in the premises of **Kamarajar Port Limited, Ennore, Tamil Nadu on 25th November, 2020.**

| S. No. | Description of Work | Indicative value of work (Rs) inclusive of GST | EMD / Bid Security Value (Rs) | Period of Completion |
|--------|---|--|-------------------------------|----------------------|
| 1 | Construction of Road adjacent to IOCL (L&G) Regasification Terminal Road (inside the KPL) Km:0/000 to Km:2/410 | 1726 Lakhs | 17,26,000/- | 18 months |

Bid document can be obtained between **10.00 hrs and 17.00 hrs** on all working days from **22nd October 2020 to 24th November 2020** at the address for communication mentioned below on payment of Non-refundable fee of **Rs.28,000/- (Rupees Twenty Eight Thousand Only) inclusive of GST** in the form of a Demand Draft drawn in favour of **M/s.Tamil Nadu Road Development Company Ltd. (TNRDC)** payable on any scheduled bank in **Chennai**. Alternatively, the Bid document can also be downloaded from the website www.tnrdc.com and in such cases, the bidders will be required to pay the non-refundable fee as mentioned above, at the time of submission of Bids. The bids shall be submitted through **Two Cover System (Technical and Financial Bids in separate envelopes)**

Sealed bids should reach at the following address not later than **15.00 hrs on 25th November 2020**. The **Technical Bid** will be opened on the same day at **15.30 hrs** in TNRDC's Corporate Office and the date for opening of Financial Bid will be intimated later.

Address for communication

Chief General Manager

M/s.Tamil Nadu Road Development Company Ltd.,

No.171, II Floor, Tamil Nadu Maritime Board Building,

South Kesavaperumal Puram,

Pasumpon Muthuramalingam Road,

(Near Greenways Road MRTS Station),

Raja Annamalai Puram, Chennai 600 028

Phone: 91-44-2495 2800 / 3800,

Fax : 91-44-2493 3800

E-Mail: tenders@tnrdc.com

Web : www.tnrdc.com

Section I

Instructions to Bidders

SECTION 1: INSTRUCTIONS TO BIDDERS**A: GENERAL****1. Scope of Bid****1.1 Background**

- (a) **M/s Tamil Nadu Road Development Company Ltd. (TNRDC)** is promoted by Tamil Nadu Industrial Development Corporation Ltd (TIDCO) and TIDEL Park Ltd.

Bids are invited by **M/s Tamil Nadu Road Development Company Ltd (TNRDC)**, for **“Construction of Road adjacent to IOCL (L&G) Regasification Terminal Road (inside the KPL) Km:0/000 to Km:2/410”** from independent firms.

- (b) M/s Kamarajar Port Limited(KPL) requested to take up the above work on deposit system and TNRDC invites Bids using the deposit of KPL.
- (c) The estimated civil cost of the work is **Rs.1726 Lakhs**.
- (d) All the Terms and conditions stipulated in this Bid Document and its annexure thereof are applicable to the work.

1.1.2 The successful bidder will be expected to carry out the work for a period of **18 months** from the date of Contract Agreement.

1.1.3 The execution of the above works is on “Item Rate Contract basis”. The approximate quantities for items of works to be executed are furnished in the Bill of Quantities (BoQ) - Section- V of the bidding document.

1.2 Scope of works

1.2.1 The broad scope of Works to be carried out by the selected bidder includes the following components, but not limited to :

- **“Construction of Road adjacent to IOCL (L&G) Regasification Terminal Road (inside the KPL) Km:0/000 to Km:2/410”**
- Other works and services as may be indicated in the contract.

1.2.2 The Details of the above work are as follows:

| S. No | Description of Works | Indicative value of work (Rs) | EMD / Bid Security Value (Rs) | Period of Completion |
|--------------|---|--------------------------------------|--------------------------------------|-----------------------------|
| 1 | Construction of Road adjacent to IOCL (L&G) Regasification Terminal Road (inside the KPL) Km:0/000 to Km:2/410 | 1726 Lakhs | 17,26,000/- | 18 Months |

The Cost of the Bid document for the work is **Rs.28,000/- (Rupees Twenty Eight Thousand Only)** which is Non-Refundable as indicated in clause 5. EMD should be attached as prescribed in Clause 15.

Any bid not accompanied by the Bid Document duly signed in all pages and its acceptable Cost and EMD, shall be summarily rejected by the Employer as **Non- Responsive**.

2. Throughout this Bidding document, the term 'bid' and 'tender' and their derivatives (bidder/ tenderer, bid/ tender, bidding/ tendering, etc.) are synonymous.

3. Eligible Bidders

3.1 Qualification of the Bidder

To be qualified for award of the contract, bidders shall provide evidence satisfactory to the Employer of their capability and adequacy of resources to carry out the contract effectively.

- 3.2 Bids shall include the following relevant information & particulars in the prescribed forms attached in Section –II: Forms of bid & Forms of securities.

- (a) Copies of original documents defining the constitution or legal status, place of registration and principal places of business; written Power of Attorney of the signatory of the Bid to commit the bidder;
- (b) Total Annual Turnover in the civil works construction business expressed as total of payment certificates for work performed in each for the last five years;
- (c) Performance as Contractor, on works of a similar nature and complexity over the last five years and details of other work on hand and contractual commitments;
- (d) Major items of Contractor's equipments proposed for carrying out the contract;
- (e) The qualifications and experience of key personnel proposed for administration and execution of the contract.
- (f) Reports on the financial standing of the bidder including profit and loss statements, balance sheets and auditor's reports for the past five years.
- (g) Authority to seek references from the bidder's bankers;
- (h) Information regarding any litigation or arbitration resulting from contracts executed by the bidder in the last three years or currently under execution. The information shall include the names of the parties concerned, the disputed amount, cause of litigation, and matter in dispute;
- (i) Proposal of work methods, in sufficient detail to demonstrate the adequacy of the bidder's proposals to meet the technical specifications and the completion time referred in sub-clause 1.1.2 above.
- (j) Should have adequate labour resources / link with manpower agencies to supply the required labourers and equipment for the work.
- (k) The Bidder should have **GST Registered No. & ESI or Workmen Compensation Policy and EPF code**. However, the Successful bidder has to furnish **GST Registered**

No. & ESI / Workmen Compensation Policy and EPF code subsequent to which payment for the work done will be released.

- (l) The bidder should remit workmen compensation cess at the rate of 1% on the estimate amount as per notification under sub-section (1) of section 8-A of the Tamil Nadu Manual workers (Regulation of Employment and Conditions of Work) Act, 1982 (Tamil Nadu Act 33 of 1982) the Governor of Tamil Nadu, in supersession of the Labour and Employment Labour and Employment Department Notification No. II (2)/LE/1420(b-1)/97, published at page 1 of part-II – Section 2 of the Tamil Nadu Government Gazette Extraordinary dated 2nd July 1997 as contribution to the fund constituted for the benefit of the manual workers under employment in construction or maintenance of dams, bridges, roads or in any building operations under section 3 of the said Act before execution of the Agreement as per the format prescribed in appendix 3

- 3.3 Bidders shall not be under a declaration of ineligibility or blacklisted for corrupt and fraudulent practices or poor quality/ delayed implementation of any work by the Government of India (GoI), Government of Tamil Nadu (GoTN), other State Governments or any other agencies and/ or Statutory Authorities.

4. Qualification Criteria and Information

The Qualification will be based on the bidder who meets the following criteria with respect to general and particular experience, financial position, personnel, and equipment capabilities and other relevant information as given by the applicant in the required format.

The following criteria must be fulfilled by the Bidder and the same shall be duly certified by auditors clients, as applicable. The Bidder shall note that the criteria set out hereunder shall be satisfied by the Bidder.

4.1 Experience and Turn Over

The bidder shall provide documentary evidence of having been actively engaged in the civil works of similar nature during the last five years in the role of contractor.

4.2 Particular Construction Experience

The bidder shall provide evidence that the firm has successfully completed or substantially completed during last five years (year 2015-2016, 2016-2017, 2017-2018, 2018-2019 & 2019-2020) a single civil work contract of similar nature for a minimum value of **Rs.690.40 Lakhs**

This experience in similar nature of work should also include the following minimum quantities of works completed in one year during the last five years.

The important /major items involved in the work which warrants prequalification, may be prescribed, as deems fit.

| S.No. | Name of the Item | Quantity | Unit |
|-------|---------------------------------|----------|------|
| 1 | Cement Concrete (PCC, RCC &PQC) | 4900 | cum |

| | | | |
|---|--|-------|-----|
| 2 | Earthwork embankment, subgrade, earthen shoulder | 12600 | cum |
| 3 | GSB | 2900 | cum |

The bidder will indicate the details of work executed project wise in a summary sheet separately.

The Contractor should have sufficient tools and Plants to complete this work.

The Contractor should have required bid capacity to execute this work

4.2.1 ESCALATION

The following enhancement factors shall be used for the costs of works executed and the financial figures to a common base value for similar works completed in India.

Multiplying factor

| | Year | Rate of inflation |
|---------|-------------|-------------------|
| Current | | |
| Year 1 | 2019-2020 | 1.0000 |
| Year 2 | 2018 - 2019 | 1.0600 |
| Year 3 | 2017 - 2018 | 1.1236 |
| Year 4 | 2016 - 2017 | 1.1910 |
| Year 5 | 2015 – 2016 | 1.2625 |

The application will indicate actual figures of costs and amounts in the schedule without accounting for the above-mentioned factors.

Note: Current year means the year assessment year (i.e.). The completed year immediately preceding the date month and year in which notice inviting tenders for prequalification is published.

4.3 Turn Over

The bidder shall have generated a minimum **Annual Average Project Related Civil work Turnover of Rs.1726 Lakhs** during the last 5 years commencing from the year, 2015-2016, 2016-2017, 2017-2018, 2018-2019 & 2019-2020.

4.4 Personnel Capabilities

The bidder shall supply general information on the management structure of the firm and shall make provision for suitably qualified personnel required for the work

The Minimum requirement of the Personnel for the project is as follows:

| Sl.No | Designation | Educational Qualification | Professional Experience in similar capacity | Minimum Requirement of Personnel |
|-------|------------------------------|------------------------------|---|----------------------------------|
| 1 | Structural/Pavement Engineer | Degree in Civil Engineering | 5 Years | 1 No |
| 2 | Highway Engineer | Degree in Civil Engineering | 5 Years | 1 No |
| 3 | Field Engineer | Diploma in Civil Engineering | 5 Years | 1 No |
| 4 | Quantity Surveyor | Diploma in Civil Engineering | 5 Years | 1 No |
| 5 | Material Engineer | Degree in Civil Engineering | 5 Years | 1 No |

The Bidder shall furnish satisfactory proof of evidence stating the qualification and experience of the above mentioned Key Personnel.

All other necessary inputs of man power such as support staffs, field technical staffs, office staffs other than the above mentioned, as deemed necessary, shall be provided by the bidder within the quoted amount to ensure that the entire work is completed in accordance with the conditions stipulated in the Bid document.

In case of non deployment of the above personnel on the part of the contractor, a penalty of **Rs.20,000/-** per month for the Diploma holder and **Rs.30,000/-** per month for the Degree holder shall be levied based on the norms for the value of this contract.

The Bidder should have **GST Reg No., ESI / Workmen Compensation Policy and EPF code**. The Bids submitted by the firms without **ESI / Workmen Compensation Policy and EPF code**, shall be declared **Non-Responsive**. However, the Successful bidder has to furnish **ESI / Workmen Compensation Policy and EPF code subsequent to which payment for the work done will be released**.

4.5 Equipment Capabilities

The bidder should own or should have assured ownership to the key items of

equipment (as per Annexure – 1), in full working order, and must demonstrate that based on known commitment, they will be available for use in the proposed contract.

4.6 Financial Capabilities

4.6.1 The bidder should demonstrate that he has access to, or has available liquid assets (working capital, cash in hand) and / or credit facilities of not less than 10% of the contract applied for the construction, cash-flow may be taken as 10% of the estimated value of contract as **Rs.172.60 Lakhs**

4.6.2 The audited balance sheet for the last five years should be submitted which must demonstrate the soundness of the bidders financial position, showing long-term profitability including an estimated financial projection for the next two years. Where necessary the Employer will make inquiries with the bidder's bankers.

4.6.3 BID CAPACITY

The bidder who meet the minimum qualification criteria will be qualified only if their available bid capacity at the expected time of bidding is more than the total estimated cost of the works. The available bid capacity will be calculated as under :

Assessed available bid capacity = $(A \times N \times 2 - B)$

Where

A is Maximum value of construction works executed in any one year during the last five years (updated to the current price level) rate of inflation may be taken as 06% per year which will take into account the completed as well as works in progress.

B is Value at current price level of the existing commitments and ongoing works to be completed during the next ensuing months (period of completion of works for which bids are invited), and

N is Number of years prescribed for completion of the works for which the bids are invited,

Even though the Bidders meet the above criteria, they are subject to be disqualified if they have :

Made misleading or false representation in the form, statements and attachment submitted, and/or

Records of poor performance such as abandoning the work, rescinding of contract for which the reasons are attributable to the non-performance of the contractor, consistent history of litigation awarded against the bidder or financial failure due to bankruptcy.

NOTE:

Copies of the documentary evidence to be furnished in support of the pre-qualification requirements should be submitted with due attestation by the competent authority.

The tenderers should furnish the original documents when called for at the time of tender evaluation to verify the copies of documentary evidence furnished along with the pre-qualification documents

The audited balance sheet /profit and loss account etc., to be furnished by the tenderer should be properly endorsed by the auditors as verified with reference to the particulars furnished by the individual and found to be correct.

4.6.4 CHECK LIST FOR INFORMATION TO BE FURNISHED

The documents submitted by the Bidders should be properly indexed. All pages shall be numbered and an Index sheet added in the beginning of Bidding Documents.

Current bid capacity should be worked out by the Bidder in accordance with Para 4.6.3 above and furnished in Application Form (11). All documents in support of the figures used in working out the Bid Capacity should be attached along with. The five-year period to be used in working out bid capacity and the factors for indexing shall be as below.

A duly filled up check list shall be enclosed as per the proforma given below. This shall be added to the index sheet

| | Name of the Document | Whether submitted Y/N | If yes, Refer Page No. | If No, Give Reasons |
|--|---|-----------------------|------------------------|---------------------|
| | Audited financial statements consisting of profit and loss statements, balance sheets and details about turnover from Civil Engineering works for preceding five years. | | | |
| | Extent of access to bank loans or credit facilities with ceiling limits, if any, prescribed in this regard and certified by the banker themselves. | | | |
| | Details of current work in progress including value of current outstanding payables, etc. | | | |
| | Certificates from competent authority | | | |
| | Provisional program for completion of various activities | | | |
| | Application from (1) to (10) | | | |
| | Calculation for current bid capacity | | | |
| | Latest Income tax Clearance Certificate | | | |
| | Power of attorney / Authorization for Persons signing the Tender For Signing the Tender For Partner – in- charge | | | |
| | Summary of quantities of work executed project wise | | | |

4.6.5 NOTE

The Language in which the contract will be executed and operated will be in English and the law governing the contract will be the Indian Law.

4.6.6 GENERAL

The intending tenderers are requested to go through the Bid documents regarding the instructions to bidders, general conditions of contract, special conditions of contract for Technical specification, boq, contract data, form of bid and bid security, further security of quantities, drawings etc.,

Pre-Qualification questionnaire complete in all respects should be submitted with tenders in a separate covers, along with EMD in prescribed format.

No costs incurred by the contractors in making their offers in providing clarification or attending discussions, conferences (or) site visits will be, reimbursed by Employer or the Engineer Incomplete offers are liable to be rejected. The language for submissions of the bid should be in English.

The enclosed schedules should be filled in completely and all questions should be answered if a particular query is not relevant, it should be state as "Not applicable". Financial data, Project costs, Value of work etc. should be given in Indian Rupees only.

For any clarification the CGM / TNRDC may be contacted on all working day at working hours.

If the application is made by a firm in partnership of the firm, their full names and current addresses or by a partner holding the power of attorney for the firm by signing the application in which case a certified copy of the power of attorney shall accompany the application. A certified copy of the partnership deed, current address of the firm and the full names, and current addresses of all the partners of the firm shall also accompany the application.

If the application is made by a limited company or a limited corporation it shall be signed by a duly authorized person holding the power of attorney for signing the application in which case a certified copy of the power of attorney shall accompany the application. Such limited company or corporation will be required to furnish satisfactory evidence of its existence before the contract is awarded.

To be eligible for award of contract bid document shall provide evidence satisfactory to the employer, not withstanding any previously conducted pre-qualification of potential bidders of their capability and adequacy of resources effectively to carry out subject contract. To this end all bid submitted shall include the following information.

- a) Copies of the original document defining the constitution of legal status and principal places of business of the company firm or partnership thereto constituting tenderer.

Major items of construction equipments for carrying out the contract in format prescribed in Annexure – I. The bidders shall furnish the registration number, Engine number and make number of tools and plants to be employed exclusively for this work. The qualification and experience of key personnel proposed for work, status and execution of the contract both in and off site, in the format prescribed in Annexure II A & B.

The reports of the financial status under including profit and loss statement, balance sheet and auditor report for the past 5 years an estimated financial projection for the next two years and an authority from the tenderer to seek reference from their Banker should be furnished.

Information, regarding any current Litigation in which the tenderer involved.

The information furnished must be sufficient to show that the Bidder is capable in all respects to successfully complete the envisaged contract works strictly on the basis of the Bidder having already earlier carried out satisfactorily work similar size nature and complexity.

All recipients of pre-qualification documents (whether they submit pre – qualification bid or not) should treat the documents as strictly confidential.

The Bidder is expected to have visited the project site before submitting bid.

While submitting the schedules duly filled in the Bidder shall enclose copies of brochures and technical documentation giving more information about the firm and all members of the consortium.

For the purpose of tender evaluation a substantially responsive tender is one which confirms pre-qualification particulars.

If the tender is not substantially responsive to the requirement of the pre-qualification particulars and it will be rejected by the employer and may not subsequently be made responsive by the tenderer having given additional particulars

4.7 Litigation History

The bidder as on date should not have been debarred from taking up any civil construction works and shall not be under a declaration of ineligibility for corrupt and fraudulent practices by the Government of India, Government of Tamil Nadu or any other agency. The bidder should provide accurate information about any litigation or arbitration resulting from contracts completed or ongoing under its execution over the last three years. A consistent history of awards against the bidder will result in rejection of the bid. Suppression of any information or material in this regard would be construed as a fundamental breach and TNRDC reserves its right to take appropriate action including cancellation of the bid, forfeiting of bid security etc., as may be deemed fit by TNRDC at any time without requiring to give any notice to the applicant in this regard.

4.8 Deleted

4.9 Construction Programme

The Bidder shall submit details of proposed construction programme regarding work methodology including preliminary Environment Management Plan, Traffic Management Plan and Resource Management Plan.

The Bidder shall, pay special attention and concentrate on the following issues wherever mentioned throughout bid document and propose the construction programme accordingly:

- i) Test inspection and rejection of defective materials on work.
- ii) Carriage
- iii) Construction Plant
- iv) Water and Lighting
- v) Cleaning up during progress and for delivery
- vi) Accidents
- vii) Delays
- viii) Particulars of Payment

5. Cost of Bid document

The cost of bid document is **Rs.28,000/- (Rupees Twenty Eight Thousand Only)** which is Non-Refundable as indicated in the Invitation for Bids. Any bid not accompanied by the acceptable bid document duly signed in all pages and its cost will be rejected by the employer as **Non-Responsive**.

The bidder shall bear all costs associated with the preparation and submission of his Bid, and the Employer will in no case be responsible and liable for such costs, regardless of the conduct or outcome of the tendering process.

6. Site Visit

The Bidder shall, prior to submission of the Bid for the work, at his own expense, responsibility and risk, is encouraged to visit and examine the Site of Works and its surroundings and obtain all information that may be necessary for preparing the Bid and entering into a contract for construction of the works.

B. BIDDING DOCUMENT

7. Contents of the Bid Document

The contents of the Bid documents are given in the succeeding paragraphs

7.1 The Bidding Document comprises the documents listed below and should be read in conjunction with any addenda issued in accordance with Clause 9

- (a) Section I Instructions to Bidders
- (b) Section II Forms of Bid and Forms of Securities
- (c) Section III Conditions of Contract
- (d) Section IV Contract Data
- (e) Section V Bill of Quantities (BoQ)
- (f) Section VI Drawings
- (g) Section VII Technical Specifications

- 7.2 The Bidder is expected to examine carefully all instructions, qualification information, forms, Conditions of Contract, Contract Data, Technical specifications, forms, BoQ, and Drawings in the Bid Document. Failure to comply with the requirements of Bid Document shall be at Bidder's own risk. Pursuant to Clause 25.2, bids, which are not substantially responsive to the requirements of the Bid Document, will be rejected.

8. Clarification of Bidding Document

8.1 Pre Bid Meeting;-

Pre-Bid Meeting shall be held at TNRDC's Corporate Office on 06th November, 2020 at 15:00 hrs. Bidders wanting to have their queries answered in Pre-Bid Conference or bidders wanting any other clarifications should send their queries on or before 02nd November, 2020. A Prospective bidder requiring any clarification on the bidding documents may notify the Employer in writing or by cable (hereinafter the term "cable" is deemed to include telex and facsimile) at the Employer's address mentioned below. The Employer will respond to any request for clarification **on or before 16th November, 2020 up to 15.00 Hrs.**

The Address for requesting clarification is:

**Chief General Manager
M/s.Tamil Nadu Road Development Company Limited,
171, 2nd Floor, Tamil Nadu Maritime Board Building,
South Kesavaperumal Puram,
Pasumpon Muthuramalingam Road (Greenways Road),
Raja Annamalai Puram,
Chennai – 600 028**

Only those parties who have purchased the Bid document shall be allowed to participate in the Pre-Bid conference. Applicants who have downloaded the Bid document from TNRDC's website (www.tnrdc.com) should submit a non-refundable Demand Draft of Rs.28,000/- (Rupees Twenty Eight Thousand Only) drawn in favour of M/s. Tamil Nadu Road Development Company Ltd, payable at any scheduled bank in Chennai, towards the cost of Bid Document, through their representative attending the Pre Bid conference. A maximum of two representatives of each Bidder shall be allowed to participate on production of authorisation letter from the Bidder. The bidder who have neither purchased the document nor produced the document cost at the time of Pre Bid meeting will not be allowed to participate.

It is the bidder's responsibility (For those who download the bid Document from the website) to keep track of the website specified in the NIT for Response to Pre Bid Queries and/or any addendum. The Response to Pre Bid Queries and/or any Addendum shall form part of this Bid document.

The purpose of the meeting will be to clarify issues and to answer questions on any matter regarding the work that may be raised on or before the date of pre-bid

meeting.

9. Amendment of Bidding Document

- 9.1 Before the deadline for submission of bids, the Employer may modify the bidding documents by issuing addenda.
- 9.2 Any addendum thus issued shall form part of the bidding documents and shall be communicated to all the purchasers of the bidding documents and it will also be uploaded in the website. It is the bidder's responsibility (for those who download from the website) to keep track of the website specified in the NIT for any addendum. The addendum of the bidding document will not be notified in the newspaper. Prospective bidders shall acknowledge receipt of each addendum by post or fax or e-mail to the Employer.
- 9.3 To give prospective bidders reasonable time in which to take an addendum into account in preparing their bids, the Employer may, at his discretion, extend the deadline for submission of bids, in accordance with Sub-Clause 19.2.

C. PREPARATION OF BIDS

10. Language of the Bid

- 10.1 The bid, and all correspondence and document related to the bid exchanged between the Bidder and the Employer shall be written in **English** language.

The Bidders shall submit separate, sealed envelopes comprising of Technical Bid and Financial Bid as detailed in clause 11 below.

11. Documents Comprising the Bid

- 11.1 The bid shall be prepared and complete in accordance with the provisions of the Bid Document and shall be submitted by the bidder in a duly sealed and signed manner as appropriate. It shall comprise the following:

(a) TECHNICAL BID (Envelope No.1) :

- (i) Bidder's qualification and other information and supporting documents of Clause 4 as per the formats given in Section-II of Bid Document
- (ii) Earnest Money Deposit (EMD) as per Clause 15.1
- (iii) Bid Document and its cost as per Clause 5

The Technical Bid must not include any details of Financial Bid and the Financial Bid must not include any details of Technical Bid.

(b) FINANCIAL BID (Envelope No.2) :

- (i) Letter of Financial Bid as per the format given in Section-II of Bid Document, and
- (ii) Bill of Quantities as given in Section-V of Bid Document.

11.2 The '**BID**' must be in a bound form with pages numbered serially and by giving an index of submissions. The forms and schedules given in Section-II, and Section-V shall be filled in without exception and without any variation, both in respect of form and contents. **Any bid not bound and if submitted in loose papers shall be summarily rejected.**

11.3 All the addenda issued should be properly incorporated. Failure to do so may result in the bid being rejected.

12. Bid Prices

12.1 Unless stated otherwise in the bidding documents, the contract shall be for the whole work or parts thereof as described in Sub-Clause 1, based on the quoted rates in Bill of Quantities submitted by the Bidder.

12.2 The bidder shall fill in rates and prices on unit basis (both in figures and words) for all items of the works described in the Bill of Quantities along with total bid price (both in figures and words). Items for which no rate or price is entered by the bidder will not be paid for by the Employer when executed and shall be deemed covered by the other rates and prices in the Bill of Quantities. Corrections, if any, shall be made by crossing out, initialling, dating and rewriting.

12.3 All duties, taxes (including GST), fees, tolls, royalties, cess and octroi, insurance, contribution to labour welfare fund, EPF and other levies payable by the contractor under the contract, or for any other cause shall be included in the rates, prices and total Bid Price submitted by the Bidder.

12.4 The rates and prices quoted by the Bidder shall be fixed for the duration of the Contract and shall not be subject to adjustment on any account.

13 Currencies of Bid and Payment

The unit rates and the prices shall be quoted by the bidder entirely in **Indian Rupees only**.

All payments shall be paid in Indian Rupees only.

14 Bid Validity

14.1 Bids shall remain valid for a period of **180 days (One Hundred and Eighty days)** after the deadline date for Bids as specified in Clause 19. A bid valid for a shorter period shall be rejected by the Employer as **Non-Responsive**.

14.2 In exceptional circumstances, prior to expiry of the original time limit, the Employer may request the bidders to extend the period of validity for a specified additional period. The request and the bidder's responses shall be made in writing or by cable. A bidder may refuse the request without forfeiting his bid security. A bidder agreeing to the request will not be required or permitted to modify his bid, but will be required to extend the validity of his bid security for the period of the extension, and in compliance 19.2 in all respects.

15 Earnest Money Deposit (EMD)

- 15.1 The proposals duly filled in the required format must reach the Office of TNRDC, **No.171, II Floor, Tamil Nadu Maritime Board Building, South Kesavaperumal Puram, Pasumpon Muthuramalingam Road, (Near Greenways Road MRTS Station), Raja Annamalai Puram, Chennai - 600 028** on or before **15.00 hrs, on 25th November, 2020** along with **EMD/ Bid Security for an amount of Rs.17,26,000/-** in one of the following forms:
- i) Form of **Demand Draft** drawn in favour of **M/s. Tamil Nadu Road Development Company Ltd**, as indicated in the bid document.
 - ii) **Bank Guarantee** from any Nationalised Indian Bank / Scheduled Bank approved by the RBI.
 - iii) The Bank Guarantees issued, as surety for the bid shall be valid for 28 days beyond the validity of the bid.

15.2 **Any bid not accompanied by the acceptable EMD shall be rejected by the Employer as Non- Responsive.**

16 Deleted.

17 Format and Signing of Bid

- 17.1 Only relevant supporting documents shall be submitted along with the Bid, Documents furnishing additional information other than that is required as per Bid Document, if any, shall be submitted separately under separate heading, which may not be considered for evaluation.
- 17.2 The entire Bid including covering letter and supporting documents shall be duly page numbered and shall contain a detailed table of contents with page references.
- 17.3 The person or persons signing the Bids shall initial all pages of the Bids.
- 17.4 The Bid shall be typed or written in indelible ink and shall be signed by a person or persons duly authorized to sign on behalf of the Bidder. All pages of the bid where entries or amendments have been made shall be initialled by the person or persons signing the bid.
- 17.5 The Bid shall contain no alterations or additions, except those to comply with instructions issued by the Employer, or as necessary to correct errors made by the bidder, in which case such corrections shall be initialled by the person or persons signing the bid.
- 17.6 The Bidder shall furnish information as described in the Form of Bid and Qualification on commissions or gratuities, if any, paid or to be paid to agents, and to contract execution if the Bidder is awarded the contract.
- 17.7 All witnesses and sureties shall be persons of status and probity and their full names, occupation and addresses shall be printed below their dated signatures.

D. SUBMISSION OF BIDS

18 Sealing and Marking of Bids

18.1 The Bidder shall submit Technical Bid and Financial Bid in two separate envelopes, securely sealed. These envelopes shall be clearly marked on top as “**TECHNICAL BID**” and “**FINANCIAL BID**” as appropriate. The Technical Bid and Financial Bid in two separate envelopes so sealed and marked shall then be put into **an Outer Envelope** duly sealed.

18.2 The **Inner and Outer** envelopes shall

(a) be addressed to the Employer at the following address:

**Chief General Manager
M/s Tamil Nadu Road Development Company Ltd.
171, 2nd Floor TNMB Building,
South Kesavaperumalpuram,
Pasumpon Muthuramalingam Road ,
(Near Greenways Road MRTS Station)
Raja Annamalaipuram, Chennai- 600 028**

And

(b) bear the following identification:

Bid for “ **Construction of Road adjacent to IOCL (L&G) Regasification Terminal Road (inside the KPL) Km:0/000 to Km:2/410**”

18.3 In addition to the identification mentioned above, the inner and outer envelopes shall indicate the name and address of the bidder to enable the bid to be returned unopened in case it is declared late, pursuant to Clause 20.

18.4 If the envelopes are not sealed and marked as above, the Employer will assume no responsibility for misplacement or premature opening of the bid and the bid will be rejected on the grounds of **Not Substantially Responsive.**

19 Deadline for Submission of the Bids

19.1 Bids must be received by the Employer at the address specified above not later than **15.00 Hours on 25th November, 2020.** In the event of the specified date for the submission of bids declared a holiday for the Employer, the Bids will be received up to the appointed time on the next working day.

19.2 The Employer may extend the deadline for submission of bids by issuing an amendment in accordance with Clause 9, in which case all rights and obligations of the Employer and the bidders previously subject to the original deadline will then be subject to the new deadline.

20 Late Submission of Bids

Any Bid received by the Employer after the deadline prescribed in Clause 19 will be returned unopened to the bidder.

21 Deleted

E. BID OPENING AND EVALUATION

22 Bid Opening

- 22.1 The Employer will open all the Bids received (except those received late), pursuant to Clause 19, in the presence of the Bidders or their Authorised Representatives with Authorisation Letter from the firm to attend the Bid opening who choose to be present **at 15:30 Hrs on 25th November 2020** at the office of the TNRDC, RA Puram, Chennai.
- 22.2 In the event of the specified date of Bid opening being declared a holiday, the Bids will be opened at the appointed time and location on the next working day by the employer.
- 22.3 Deleted
- 22.4 After opening of the outer envelope containing the Bid, its contents shall be examined for compliance in pursuant to Clause 18.1. Bids found not complying are liable to be rejected without further examination. The contents of envelope titled "**TECHNICAL BID**" will be opened first and its contents shall be scrutinised as per requirements of Bid document for initial responsiveness. Only for the Bidders, whose Technical Bid contains the requisite Bid Document Cost, acceptable EMD / Bid security and the Technical Bid along with the Bid document and if found in order and evaluated as substantially responsive, the envelope titled "**FINANCIAL BID**" shall be opened. TNRDC may notify those bidders whose bids were not considered as per conditions of the bid document and will return their Financial Bid "unopened" along with the EMD. TNRDC shall simultaneously notify the technically qualified bidders indicating the date and time set for opening of the Financial Bid. The financial bid will be opened **at the same address as specified in Clause 18.2** in the presence of Bidders or their authorized representatives with Authorisation letter from the firm to attend the financial bid opening who choose to be present.

The Tender scrutiny Committee will determine whether the submitted Financial bid is complete i.e. whether they have included cost of all items; if not, then the cost towards such missing items will be considered as NIL, but, the bidder shall, however, be required to carry out such obligations without any additional compensation. In case under such circumstances, if TNRDC feels that the work cannot be carried out within the overall cost as per the submitted financial bid, such bid shall be considered **Non - Responsive**.

- 22.5 The Bidder's names, the Bid Prices, the total amount of each bid, any discounts, and such other details as the Employer may consider appropriate, will be announced and recorded by the Employer at the time of opening. No bid shall be rejected at the time of Bid opening except for late bids pursuant to Clause 20 and conditional bids. Bids that are not opened and read out at Bid opening will not be considered for further evaluation regardless of the circumstances. Late bids will be returned unopened to Bidders along with the EMD submitted by them.

23 Process to be Confidential

Information relating to the examination, clarification, evaluation, and comparison of Bids and recommendations for the award of a contract shall not be disclosed to Bidders or any other persons not officially concerned with such process until the award to the

successful Bidder has been announced. Any effort by a Bidder to influence the Employer's processing of Bids or award decisions may result in the rejection of his Bid.

24 Clarification of Bids

- 24.1 To assist in the examination, evaluation, and comparison of Bids, the Employer may, at his discretion, ask any Bidder for clarification of his Bid, including breakdowns of the unit rates. The request for clarification and the response shall be in writing or by cable, but no change in the price or substance of the Bid shall be sought, offered, or permitted except as required to confirm the correction of arithmetic errors discovered by the Employer in the evaluation of the Bids in accordance with Clause 27. Provided however, the employer shall seek the rectification of price with the bidder who quoted lowest in total;
- 24.2 Subject to sub-clause 24.1, no Bidder shall contact the Employer/ its representatives on any matter relating to its bid from the time of the bid opening to the time the contract is awarded.
- 24.3 Any effort by the Bidder to influence the Employer in the Employer's bid evaluation, bid comparison or contract award decisions may result in the rejection of the Bidder's bid.

25 Preliminary Examination of Bids and Determination of Responsiveness

- 25.1 Prior to the detailed evaluation of Bids, the Employer will determine whether each Bid (a) has been properly signed; (b) is accompanied by the required securities and; (c) is substantially responsive to the requirements of the Bidding documents pursuant to Clause 22.4; and (d) provides any clarification and/ or substantiation that the Employer may require pursuant to Clause 24.
- 25.2 A substantially responsive Bid is one, which conforms to all the terms, conditions, and specifications of the Bidding documents, without material deviation or reservation. A material deviation or reservation is one (a) which affects in any substantial way the scope, quality, or performance of the Works; (b) which limits in any substantial way, inconsistent with the Bidding documents, the Employer's rights or the Bidder's obligations under the Contract; (c) not confirming to the requirement at Clause 18 or (d) whose rectification would affect unfairly the competitive position of other Bidders presenting substantially responsive Bids.
- 25.3 If a Bid is not substantially responsive, it will be rejected by the Employer, and may not subsequently be made responsive by correction of the non-conforming deviation or reservation.

26 Correction of Errors

- 26.1 Bids determined to be substantially responsive will be checked by the Employer for any arithmetic errors. Errors will be corrected by the Employer, where there is a discrepancy between the unit rates in figures and in words, the lesser of the two will prevail.

26.2 The amount stated in the Bid will be adjusted by the Employer in accordance with the above procedure for the correction of errors and, with the concurrence of the Bidder, shall be considered as binding upon the Bidder. If the Bidder does not accept the corrected amount the Bid, will be rejected, and the Bid security may be forfeited in accordance with Sub-Clause 17.6.

27 Evaluation and Comparison of Bids

27.1 The Employer will evaluate and compare only the Bids determined to be substantially responsive in accordance with Clause 25.

27.2 In evaluating the Bids, the Employer will determine for each Bid, the evaluated Bid Price by adjusting the Bid Price as follows:

- (a) Making any correction for errors pursuant to Clause 26;
- (b) Excluding Provisional Sums and the provision, if any, for contingencies in the Summary Bill of Quantities;

27.3 Towards evaluation, the employer will take into account the adjusted Bid Price for construction/ improvement works arrive at the lowest evaluated rate of bid.

27.4 The Employer reserves the right to accept or reject any variation, deviation, or alternative offer and other factors which are in excess of the requirements of the Bidding document or otherwise result in the accrual of unsolicited benefits to the Employer shall not be taken into account in Bid evaluation.

27.5 If the Bid of the successful Bidder is seriously unbalanced in relation to or substantially below the Employer's estimate of the cost of work to be performed under the contract, the Employer may require the Bidder to produce detailed price analysis for any or all items of the Bill of Quantities, to demonstrate the internal consistency of those prices with the construction methods and schedule proposed. After evaluation of the price analysis, the Employer may require that the amount of the performance security set forth in Clause 31 be increased at the expense of the successful Bidder to a level sufficient to protect the Employer against financial loss in the event of default of the successful Bidder under the Contract.

F. AWARD OF CONTRACT

28 Award Criteria

Subject to Clause 27, the Employer will award the Contract to the Bidder whose Bid has been determined to be substantially responsive to the Bidding documents and whose bids are evaluated to be the lowest, provided that such Bidder has been determined to be eligible and qualifying in accordance with the provisions of Clause 1, 3 and 4.

Prior to the expiration period of validity of proposal, TNRDC shall notify the successful firm who submitted the lowest bid in writing by registered letter of facsimile and may either issue LOA if negotiations are not required or may invite it to negotiate the contract price.

If the lowest bidder is not responding for further negotiations, the Employer reserves the right to negotiate with any of the eligible bidders who is willing to offer a negotiated and reasonable rate.

Awarding the work to bidders or summarily rejecting all the bids or to annul the bid process at any stage shall be the sole discretion of TNRDC, based on the capability of the Bidders.

Employer reserves the right to appoint other contractor/contractors for “ **Construction of Road adjacent to IOCL (L&G) Regasification Terminal Road (inside the KPL) Km:0/000 to Km:2/410**” or part of this work/contract and any other works that the Employer may decide.

29 Employer's Right to accept any Bid and to reject any or all Bids

- 29.1 Notwithstanding Clause 28, the Employer reserves the right to accept or reject any Bid, and to annul the Bidding process and reject all Bids, at any time prior to the award of Contract, without thereby incurring any liability to the affected Bidder or Bidders or any obligation to inform the affected Bidder or Bidders of the grounds for the Employer's action.

30. Notification of Award

- 30.1 The Bidder whose Bid has been accepted will be notified of the award by the Employer prior to expiration of the Bid validity period by cable, telex or facsimile confirmed by registered letter. This letter (hereinafter and in the *Conditions of Contract* called the "Letter of Acceptance") will state the sum that the Employer will pay the Contractor in consideration of the execution, completion, and maintenance of the Works by the Contractor as prescribed by the Contract (hereinafter and in the Contract called the "Contract Price").

31 Performance Security

- 31.1 Within 21 days of receipt of the Letter of Award, the successful Bidder shall deliver to the
- a. Employer a Performance Security in the form of a bank guarantee from Nationalised Bank/ Scheduled Bank acceptable to the Employer in the form as given in Section 2 for an amount equivalent to **2% of the contract price** in accordance with Clause 27.5 and Clause 48 of Conditions of Contract. The Performance Security for works shall be valid for a period of **58 Months** from the date of Bank Guarantee or **03 months** beyond the Defect Liability period whichever is later . The bidder should maintain the facility in acceptable condition as stipulated in the Bid document.
- 31.2 Failure of the successful bidder to comply with the requirements of Clause 31.1 shall constitute a breach of contract, cause for annulment of the award, forfeiture of the bid security, and any such other remedy the Employer may take under the contract.

31.3 Retention Money

In each, Interim Payment Certificate (IPC) @ 5% of value of work executed during each bill period will be withheld and the withheld amount will be refunded to the Contractor along with the Final Bill /Taking over certificate. The maximum amount of Retention money to be with held is restricted up to 5% of the contract value.

32 Signing of Agreement

- 32.1 At the same time, the employer notifies to the successful Bidder that his Bid has been accepted, and the Employer will direct him to attend the Employer's office on a date

determined by the Employer for signing the Contract Agreement as per the format provided in the Bidding Document incorporating all the agreements between the parties. The signing of the Contract Agreement shall take place only after the furnishing of the requisite performance security by the selected Bidder as per Clause 31.1

- 32.2 The Agreement will incorporate all agreements / correspondences between the Employer and the successful Bidder. It will be kept ready for signature of the successful bidder in the office of employer within 21 days following the acceptance of the Letter of Award by the successful bidder; the successful Bidder will sign the Agreement upon furnishing of the requisite performance security and deliver it to the Employer.
- 32.3 Upon furnishing of the Performance Security and signing of the Contract Agreement by the successful Bidder, the Employer will promptly notify the other Bidders that their Bids have been unsuccessful and refund the Bid Security.

33 Corrupt or Fraudulent Practices

- 33.1 The Employer requires that all the Bidders should observe the highest standard of ethics during the procurement and execution of this Contract. In pursuance of this policy, the Employer:
- (a) Defines, for the purposes of this provision, the terms set forth as follows :
- “Corrupt practice” means the offering, giving, receiving or soliciting of anything of value to influence the action of Employer/ its representatives in the procurement process or in contract execution; and
- “Fraudulent practice” means a misrepresentation of facts in order to influence a procurement process or the execution of a contract to the detriment of the Employer, and includes collusive practice among Bidders (prior to or after Bid Submission) designed to establish Bid prices at artificial non-competitive levels and deprive the Employer of the benefits of free and open competition;
- (b) will reject a proposal for award if he determines that the Bidder recommended for award has, engaged in corrupt or fraudulent, practices in competing for the Contract in question;
- (c) will declare a firm ineligible, either indefinitely by TNRDC or for a stated period of time, to be awarded any contract in **TNRDC**, if it at any time determines that the firm has engaged in corrupt or fraudulent practices in competing for, or in executing, this Contract.

34 Termination:-

In case the Contractor fails to carryout the works, as per the construction programme and as per the conditions stipulated in the Bid document, then the Employer, at its sole discretion is entitled to terminate this contract at the ‘**Risk and Cost**’ of the Contractor and to employ such other Contractor/s to carryout the balance works. The additional cost incurred by the employer in completing the works, which remain unfinished at the time of termination of the contract will be recovered from the Contractor. Any unrecovered ‘Risk and Cost’ amount will be a debt payable to the Employer and the Employer will take suitable actions for such unrecovered ‘Risk and Cost’ amount at the cost of the Contractor. Any bill/s for the works executed remains unsettled and/or the value of materials, machineries etc., taken over or possessed by

the Employer at the time of termination or on termination will be adjusted towards the 'Risk and Cost' recoverable from the contractor.

Section II
Forms of Bid &
Forms of Securities

SECTION II

FORMS OF BID & FORMS OF SECURITIES

1. LETTER OF APPLICATION

(Letterhead paper of the Bidder)

[Including full postal address, telephone, fax, cable and telex addresses]

[date]

To:

Chief General Manager

Tamil Nadu Road Development Company Limited (TNRDC)

171, 2nd Floor, Tamil Nadu Maritime Board Building,

South Kesavaperumal Puram,

Pasumpon Muthuramalingam Road (Greenways Road),

Raja Annamalai Puram, Chennai – 600 028

Sir,

1. Being duly authorised to represent and act on behalf of ----- (hereinafter called as **“The Bidder”**), and having reviewed and fully understood all the bid information provided, the undersigned hereby apply to be qualified as a bidder for the contract of **“Construction of Road adjacent to IOCL (L&G) Regasification Terminal Road (inside the KPL) Km:0/000 to Km:2/410”**.
2. TNRDC and its associates / representatives are hereby authorized to conduct any inquiries or investigations to verify the statements, documents, and information submitted in connection with this application, and to seek clarification from our bankers and clients regarding any financial and technical aspects. This Letter of Application will also serve as authorization to any individual or authorised representative of any institution, to provide such information deemed necessary to verify statements and information provided in this application or with regard to the resources, experience, and competence of the Bidder.
3. This application is made in the full understanding that:
 - (a) TNRDC reserves the right, to reject or accept any application, cancel the bidding process and reject all applications; and
 - (b) TNRDC shall not be liable for any such actions and shall be under no obligation to inform the Bidder of the grounds for them.
4. The undersigned declared that the statements made and the information provided in the duly completed application are complete, true, and correct in every detail.

Authorised Signature

Name and Title of Signatory

APPLICATION FORM (1A)

GENERAL INFORMATION

All individuals / firms applying for pre-qualification are requested to complete the information in this form. Nationality information to be provided for all Owners or Bidders who are partnerships or individually – owned firms

Where the Bidder proposes to use named sub-contractors for critical components of the works, or for works contents in excess of 10 percent of the value of the whole works the following information should also be supplied for the specialist sub-contractor(s)

| | |
|---|--|
| 1 | Name of Firm : |
| 2 | Head Office Address : |
| 3 | Contract No. |
| 4 | Telephone No. Fax No. |
| 5 | E-mail Address Telex No. |
| 6 | Incorporation / Registration Details |
| 7 | Place of incorporation: Registration Year of Incorporation / Registration |

SIGNATURE OF CONTRACTOR
CONTRACTOR CODE

APPLICATION FORM (1B)

STRUCTURE AND ORGANISATION

1. The Bidder is

| | | |
|---|----------------------------------|--|
| a | An Individual Firm | |
| b | A Proprietary Firm | |
| c | A Firm in Partnership | |
| d | A Limited Company or Corporation | |

2. Attach the Organization Chart showing the structure of organization, including the names of the Director and position of officers.

3. Number of Years of Experience :

| | | |
|----|---|--|
| a. | As a Prime Contractor (contractor Shouldering Major Responsibility) | |
| | i) In Own Country | |
| | ii) In other Countries [Specify Country(ies)] | |
| b. | As Sub-contractor (Specify Main Contractor) | |
| | i) In Own Country | |
| | ii) In other Countries [Specify Country(ies)] | |

2. a) For how many years has your organization been in the business of similar work under its present name? b) What were your fields when your organization was established? c) Whether any new fields were added in your organization? d) And if so, when?

a.

b.

c.

d.

3. a) Were you ever required to suspend construction for a period of more than six months continuously after you started? b) If so, give name of project and give reasons thereof.

a.

b.

-
4. a) Have you ever left the work awarded to you incomplete? b) If so, give name of the project and reasons for not completing work.

a.

b.

-
6. In which fields of civil engineering construction do you claim specification and interest?

7. Give details of your experience in using heavy earthmoving equipment and quality control in compaction of soils

-
8. Give details of, your soil and Materials Testing Laboratory if any
-

-
09. Give details of your experience in Mechanized granular pavement construction
-

SIGNATURE OF CONTRACTOR
CONTRACTOR CODE

10. Give detail of your experience in construction of asphaltic overlays

11. Give details of your experience in construction of Bridge works

12 Give details of your experience in construction of Bridge Work's in Open Foundations & Pile foundations.

SIGNATURE OF CONTRACTOR
CONTRACTOR CODE

APPLICATION FORM (1C)
GENERAL EXPERIENCE RECORD

Name of Bidder

| |
|--|
| |
|--|

The Bidders are requested to complete the information in this form. The information supplied should be annual turnover of the Bidder in terms of the amounts billed to Clients for each Year for work in progress or completed.

| Annual Turnover Data (Construction Works Only) | | |
|--|-------------|----------------------------------|
| S.No. | Year | Turn over (Indian Rupees) |
| 1. | | |
| 2. | | |
| 3. | | |
| 4. | | |
| 5. | | |

SIGNATURE OF CONTRACTOR
CONTRACTOR CODE

APPLICATION FORM (1D)

1. Particular Experience Record : Details of Contract of Similar Nature
(Highways and Airfields)

Name of Bidder

| |
|--|
| |
|--|

1. Use a separate sheet for each Contract

| | | |
|-----|---|--|
| 1. | a) Number of Contract | |
| | b) Name of Contract | |
| | c) Country | |
| 2. | Name of Employer | |
| 3. | Employers Address | |
| 4. | Contract Role | |
| | Sole Contractor | |
| | Sub – Contractor | |
| 5. | Value of the total Contract (at completion, or at Date of Award for current contract) | |
| 6. | Date of Award (Original and Actual) | |
| 7. | Date of completion (Original and Actual) | |
| 8. | Contract duration (Years and Months) | |
| 9. | Specify quantities of following Major items of work | |
| 1) | Cement Concrete(PCC, PQC,RCC) - 4900 cum | |
| 2) | Earthwork embankment, subgrade, earthen shoulder - 12600 cum | |
| 3) | GSB - 2900 cum | |
| 10 | Name and Professional qualification of Bidder's Engineer-in charge of the work | |
| 11. | Were there any penalties/Fines/Stop-Notice Compensation /Liquidated Damages Imposed ? (Yes or No) | |
| | If yes. give Amount and Explanation : | |

APPLICATION FORM (1E)
Current Contract Commitments / Works in Progress

Name of Firm:

| |
|--|
| |
|--|

The application should provide information on their current commitments on all contracts that have been awarded, or for which a letter of intent or acceptance has been received, or for contracts approaching completion, but for which an unqualified, full completion certificate has yet to be issued.

| Employer | Counseling Engineer Responsible for Supervision | Location and Description of the work | Value of contract in Indian Rs. | Value completed and certified in Indian Rs. | Original date of commencement of work | Original Target date of completion of work | Actual date of start work | Revised Target date of completion of work | Present progress (%) | Reason for slow progress if any |
|----------|---|--------------------------------------|---------------------------------|---|---------------------------------------|--|---------------------------|---|----------------------|---------------------------------|
| | | | | | | | | | | |
| | | | | | | | | | | |
| | | | | | | | | | | |

- a) Certificates from the Employers should be attached.
- b) Non-disclosure of any information in the schedule will result in disqualification of the firm.

SIGNATURE OF CONTRACTOR
 CONTRACTOR CODE

APPLICATION FORM (1F)

Personnel Capabilities

Name of Bidder

| |
|--|
| |
|--|

For specific position essential to contract implementation. Bidders should provide the names of at least two candidates qualified to meet the specified requirements stated for each position. The data on their experience should be supplied in separate sheet using one Form (5A) for each candidate.

| | | |
|----|-----------------------------|--|
| 1. | Title of position | |
| | Name of Prime candidate | |
| | Name of Alternate candidate | |
| 2. | Title of position | |
| | Name of Prime candidate | |
| | Name of Alternate candidate | |
| | Title of Position | |
| | Name of Prime candidate | |
| | Name of alternate candidate | |
| | Title of position | |
| | Name of Prime candidate | |
| | Name of Alternate candidate | |

SIGNATURE OF CONTRACTOR
CONTRACTOR CODE

APPLICATION FORM (1G)
CANDIDATE SUMMARY

Name of Bidder

| |
|--|
| |
|--|

| | | |
|------------------------------------|-----------------------------------|--|
| Position | Candidate | |
| | Prime | Alternate |
| Information about candidate | 1. Name of candidate | 2. Date of Birth |
| | 3. Professional Qualification : | |
| Present Employment | 4. Name and Address of employer : | |
| | Telephone No. Fax No. | Contact : (Manager / Personnel Officer) : Tele No. |
| | Job Title of candidate : | Years with present employer |

Summaries professional experience over the last 10 years. In reverse chronological Order. Indicate particular technical and managerial experience relevant to the project :

| From | To | Company / Project / Position / Relevant Technical & Managerial Experience |
|------|----|---|
| | | |
| | | |

SIGNATURE OF CONTRACTOR

APPLICATION FORM (1H)

**MAJOR ITEMS OF CONSTRUCTION PLANT AND EQUIPMENT
PROPOSED TO BE USED BY THE BIDDER ON THIS
CONTRACT**

| Description | Manufacturer & Model Type/Make | Number of each Equipment / Plant | Year of Manufacture and present condition | New or Used | Total No. of Hours of operation since date of Manufacture | Owned (O), | Estimated CIF value in Indian Rs. | Power Rating | Capacity t/hr. etc. | Present Location |
|-------------------------|--------------------------------|----------------------------------|---|-------------|---|------------|-----------------------------------|--------------|---------------------|------------------|
| General | | | | | | | | | | |
| Earthwork | | | | | | | | | | |
| Granular Construction | | | | | | | | | | |
| Bituminous Construction | | | | | | | | | | |
| Structures | | | | | | | | | | |
| Workshop Equipment | | | | | | | | | | |

The Bidder shall enter in this schedule (adding additional pages as necessary) all items of Construction Plant and Equipment which he proposes to bring on to the site on owned and shall indicate the proposed part of entry. Annexure – 1 may be referred for the list of essential plant and equipment for the work.

SIGNATURE OF CONTRACTOR
CONTRACTOR CODE

APPLICATION FORM (1I)

FINANCIAL STATEMENT

The Bidders should provide financial information to demonstrate that they meet the requirements stated in the instructions to Bidders. If necessary, use separate sheets to provide complete banker information. A copy of the audited balance sheets should be attached.

1. Name of Bidder

| |
|--|
| |
|--|

2. Summary of assets and liabilities on the basis of the audited financial statement of the last five financial years. (attach copies of the audited financial statement of the last five financial years). Based upon known commitments, summaries projected assets and liabilities in Indian Rupees for the next two years.

Firms owned by Individuals and partnerships may submit their balance sheets certified by a registered accountant and supported by copies of tax returns, if audits are not required.

| Financial information in Indian Rupees | Actual : Previous five years | | | | | Projected : Next two years | |
|--|------------------------------|--|--|--|--|----------------------------|--|
| Financial year | | | | | | | |
| Total assets | | | | | | | |
| Current assets | | | | | | | |
| Cash, temporary Investments and current receivable | | | | | | | |
| Total liabilities | | | | | | | |
| Current liabilities | | | | | | | |
| Authorized capital | | | | | | | |
| Capital issued and paid | | | | | | | |

3. Annual value of construction works, undertaken for each of the last five years and projected for current year :

| | Current Year 1 | 2 Years before | 3 Years before | 4 Years before | 5 Years before |
|--------|----------------|----------------|----------------|----------------|----------------|
| Home | | | | | |
| Abroad | | | | | |

Note 1 : Current year means the assessment year (ie) The Completed year immediately preceding the date, month and year in which notice inviting tenders for prequalification is published.

Note 2 : The projected figure for the current year shall be arrived at by applying the indexing factor as noted in Cl. 3.2

Net profit before and after Tax :

| | | |
|----|---|--|
| a) | Current period | |
| | During the last financial year | |
| | During each of the three previous financial years | |
| | Projected for the next 2 years | |

The profit and loss statements, have been certified through

_____ by

4. Specify proposed sources of financing to meet the cash flow demands of the project, net of current commitments.

| SL. NR | Source of financing | Amount in Indian Rupees |
|--------|---------------------|-------------------------|
| | | |
| | | |
| | | |

5. Credit facilities

(a) Name / address of bank providing credit line

| |
|--|
| |
|--|

(b) Total amount of credit line (attach latest certificate from the bank obtained after the tender notice publication)

| |
|--|
| |
|--|

9. (a) Approximate value of works in hand

(b) Value of existing commitment of construction works (ongoing) to be completed during the next **12 months**.

10. Value of anticipated orders for next financial year

| |
|--------|
| Home |
| |
| Abroad |
| |

11. Bid capacity computation (Give supported documents)

SIGNATURE OF CONTRACTOR
CONTRACTOR CODE

APPLICATION FORM (1K)

INFORMATION REGARDING CURRENT LITIGATION, DEBARRING / EXPELLING OF TENDERER OR ABANDONMENT OF WORK BY TENDERER

1. (a) Has the Bidder's history of litigation awarded against him ?

| | |
|-----|----|
| YES | NO |
|-----|----|

(b) If yes, give details

| |
|--------------|
| |
|--------------|

2. (a) Has the Bidder been debarred / expelled by any Agency in India, during the last 5 years, excepting on account of reasons, other than non-performance.

| | |
|-----|----|
| YES | NO |
|-----|----|

(b) If yes, give details

| |
|--------------|
| |
|--------------|

3. (a) Has the Bidder's abandoned any contract work in India, during the last 5 years ?

| | |
|-----|----|
| YES | NO |
|-----|----|

(c) If yes, give details

| |
|--------------|
| |
|--------------|

4. (a) Has the Bidder has been declared bankrupt during the last 5 years ?

| | |
|-----|----|
| YES | NO |
|-----|----|

(c) If yes, give details, including present status

| |
|----------|
| |
|----------|

| |
|--|
| |
|--|

NOTE :-

If any information in this schedule is found to be incorrect or concealed, application will be summarily rejected.

SIGNATURE OF CONTRACTOR
CONTRACTOR CODE

APPLICATION FORM (1L)

AFFIDAVIT

(Affidavit to be furnished in the Stamp Paper (as per norms) and authenticated by Notary Public)

1. The undersigned do hereby certify that all the statements made in the required attachments are true and correct.

The Undersigned also hereby certifies that our firm M/s. _____

have neither abandoned any work nor any contract awarded to us for such works have been rescinded for which the reasons were attributable to the non performance of our firm during last five years to the date of this bid.

The undersigned hereby authorize(s) and request(s) any bank person, firm or corporation to furnish pertinent information deemed necessary and request by the department to verify this statement or regarding my (our) competence and general deputation.

The undersigned understand and agrees that further qualifying information may be requested and agrees to furnish any such information at the request of the Department.

(Signed by an Authorized Officer of the Firm)

Title of Officer

Name of Firm

Date

SIGNATURE OF CONTRACTOR
CONTRACTOR CODE

2. BIDDER, QUALIFICATION AND OTHER INFORMATION

Bidders are requested to complete the information in this form through indicated formats or suitable attachments:

A. Bidder Particulars

| No. | Particulars |
|-----|---|
| (a) | Name of the Bidding Firm : |
| (b) | Status (Sole/ firm in partnership/ Pvt. or Public Ltd Company) |
| (c) | Place of incorporation/ registration : Year of incorporation/ registration : |
| (d) | Registered Head Office address/ Telephone/ Fax/ E-mail : |
| (e) | Contact Office address/ Telephone/ Fax / E-mail : |
| (f) | Contact Person and Title : |
| (g) | Names of Promoters : |
| (h) | Names of Principal Shareholders : |
| (i) | Shareholding Pattern : |

B. Details on Structure and Operation, Key Management Personnel of the Bidder's organization

(To be enclosed as an attachment)

C. Proof of Constitution of Legal Status

(To be enclosed as an attachment)

D. Power of Attorney authorizing the signatory of the Bid document to commit the Bidder
(Original or Notary Attested Photocopy to be enclosed as an attachment)**E. Auditor Certified Financial Statement by the Bidder (Annual Reports, Turnover, Liquid Assets, Banker's Details)****(i) Auditor Certified Audited Annual Reports for five years starting from Financial Year 2015-16 to Financial Year 2019-20**

[To be enclosed as an attachment)

Ref. Page Nos. _____

(ii) Annual Turnover Data for civil works (duly supported by audited Annual Reports/ Provisional Certificate for respective periods and certification by Statutory Auditors)

Turnover from Construction related works of similar nature in last five years ending March 31, 2020

| Description | | 2015-2016 | 2016-2017 | 2017-2018 | 2018-2019 | 2019-2020 |
|---|---------------|-----------|-----------|-----------|-----------|-----------|
| (a) Turnover from civil work of similar nature | Vide Page No. | | | | | |
| | Amount in INR | | | | | |
| (b) Factor for updating to 31, Mar 2020 level @ 6% pa | | 1.2625 | 1.1910 | 1.1236 | 1.0600 | 1.0000 |

| | | | | | | |
|---|--|--|--|--|--|--|
| (c) Turnover updated to Mar 31, 2020 level (a) x (b) | | | | | | |
|---|--|--|--|--|--|--|

(d) Sum of Project related Civil works turnover updated to to 31 Mar 2020, for three years INR _____

(e) Average Project related Civil works turnover for three years upto 31 Mar 2020 (updated to 31 Mar 2020 price level):

(f) **Is Average Annual Project Related Experience Turnover**
(e) > INR 1726 Lakhs INR _____

(Average Annual Turnover)

(g) Supporting documents:

| Description | Ref. Page No. |
|-------------|---------------|
| | |
| | |
| | |
| | |
| | |

(iii) **Current Liquid Assets (as on 31 March 2020 duly supported by Certificate for Financial Year 2019-2020 by Statutory Auditors)**

| Current Liquid Assets as on Mar 31, 2020 | |
|--|---------------|
| Particulars | Amount in INR |
| Working Capital | |
| Cash in Hand | |
| Uncommitted line of credit | |
| Other Financial Means | |

Supporting Documents:

| Description | Ref. Page No. |
|-------------|---------------|
| | |
| | |

(iv) **Details of Bidder’s Bankers**

| Name of the Banker | Contact Person, Contact Address, Phone number and fax number |
|--------------------|--|
| (Banker 1) | |
| (Banker 2) | |
| | |

F. Qualifying Works

For all works indicated below, the Bidder shall necessarily submit the relevant client's/ Engineer's Certificate.

| I (a) Details of qualifying single civil work contract of similar nature [as per Clause 4.2] | | | | | |
|--|------------------|------------------|------------------|------------------|------------------|
| Description | 2015-2016 | 2016-2017 | 2017-2018 | 2018-2019 | 2019-2020 |
| (a) Name of Qualifying work | | | | | |
| (b) Cost of Qualifying work (in INR) | | | | | |
| (c) Period of implementation | | | From : | To : | |
| (d) Updation factor @ 6% | 1.2625 | 1.1910 | 1.1236 | 1.0600 | 1.0000 |
| (e) Updated value of work done during period under consideration | | | | | |
| At least One civil work contract of similar nature for the value of Rs.1800 Lakhs (by any one Partner in case of JV / Consortium) | | | | | |

Supporting Documents:

| Description | Ref. Page No. |
|--------------------|----------------------|
| | |
| | |

G. Litigation / Arbitration History [as per Clause 4.7]

The Bidder shall provide the following information on history of litigation or arbitration resulting from contracts executed in the last three years or currently under execution.

Name of the Bidder: _____

| | | | |
|---|-----|--|--------------|
| 1 | (a) | Has the Applicant or its constituent partners consistent history of litigation/ arbitration awarded against / favour of him. |Yes/ No |
| | (b) | If yes, give details for each such case in the format of Table 1 below | |
| 2 | (a) | Has the applicant or any of its constituent partners been debarred/ expelled by any agency in India, during the last 3 years as on date of application, except on account of reasons other than non-performance, such as rescinding of joint venture, partner of joint venture pulling out, court directions leading to breaking up of a joint venture before start of work etc. |Yes/ No |
| | (b) | If yes, give details | |
| 3 | (a) | Has the Applicant or any of its constituent partners abandoned any contract work in India during the last 3 years |Yes/ No |

| | | | |
|---|-----|--|--------------|
| | (b) | If yes, give details |Yes/ No |
| 4 | (a) | Has the Applicant or any of its constituent partners been declared bankrupt during the last 3 years. |Yes/ No |
| | (b) | If yes, give details, including present status | |
| 5 | | Has the Applicant or any of its constituent partners been debarred by GOTN/TNRDC or any other agency in India for as on date of application. |Yes/ No |

Format for Case Summary (to be submitted by the Bidder each case pending/ settled):

| <i>Item Head</i> | <i>Particulars to be Furnished</i> |
|--|------------------------------------|
| Name of Client | |
| Year | |
| Cause of Litigation/ Arbitration/ Matter in Dispute | |
| Disputed Amount (Current Value in Indian Rupees) | |
| Resolved or pending resolution | |
| Award for or against | |
| Actual amount awarded (Current value in Indian Rupees) | |
| Other Claims Made, Settled/ Rejected | |

H. Details of Construction Program and Work Methodology (including Preliminary Environment Management Plan, Traffic Management Plan and Resource Management Plan) [as per Clause 4.9]

(To be enclosed as an attachment)

Ref Page Nos. _____

3. DECLARATION STATEMENT

(Letterhead paper of the Bidder)

[date]

To

Chief General Manager
Tamil Nadu Road Development Company Limited,
171, 2nd Floor, Tamil Nadu Maritime Board Building,
South Kesavaperumal Puram,
Pasumpon Muthuramalingam Road (Greenways Road),
Raja Annamalai Puram, Chennai – 600 028.

Dear Sir,

1. I, the undersigned, do hereby certify that all the statements made in the application and attachments thereto are true and correct.
2. The undersigned also hereby certifies that neither our firms M/s..... nor any of its constituent partners have abandoned any work awarded to us by any Agency in India nor any contract awarded to us for such works has been rescinded, during last three years prior to the date of this application.
3. The undersigned also furnish undertaking that we are not declared by any court of law as proclaimed offenders also that we are not convicted under any law for the offences punishable under Indian Penal Code, Negotiable Instrument Act of any Labour/ employee beneficial legislations.
4. The undersigned hereby authorize(s) and request(s) any bank, person, firm or corporation to furnish pertinent information deemed necessary and requested to verify this statement or regarding my (our) competence and general reputation.
5. The undersigned understands and agrees that further qualifying information may be requested, and agrees to furnish any such information at the request of TNRDC.

Signed by an Authorised Officer of the Firm

Title of Officer

Name of Firm

Date

4. LETTER OF FINANCIAL BID

(Letterhead of the Bidder)

[date]

Chief General Manager

Tamil Nadu Road Development Company Limited, (TNRDC)

171, 2nd Floor, Tamil Nadu Maritime Board Building,
South Kesavaperumal Puram,
Pasumpon Muthuramalingam Road (Greenways Road),
Raja Annamalai Puram, Chennai – 600 028

Dear Sir:

Sub: “Construction of Road adjacent to IOCL (L&G) Regasification Terminal Road (inside the KPL) Km:0/000 to Km:2/410” - Reg.

Having examined the Bid Document including Notice Inviting Bids, Instructions to Bidders, General Conditions of Contract, Special Conditions of Contract, Contract data, Technical Specifications, Bill of Quantities, Drawings, Schedules, Annexures and Addenda for the execution of the above named works, we, the undersigned, offer to execute and complete such works and remedy any defects therein in conformity with the said Bid Document at the prices indicated in the enclosed BoQ.

The Payment for

“Construction of Road adjacent to IOCL (L&G) Regasification Terminal Road (inside the KPL) Km:0/000 to Km:2/410” for the sum of **INR _____ (Indian Rupees in words)**_____)

inclusive of GST and all applicable taxes in accordance with the said Bid Document.

We undertake, if our Bid is accepted, to commence the works within fourteen (14) days of receipt of the Engineer’s order to commence, and to complete and deliver the sections and whole of the works comprised in the Contract within the period stated in the Appendix to Bid/ Contract data hereto.

We also undertake to furnish Performance Security (ie) in the form of a Bank Guarantee in accordance with the Conditions of Contract.

We agree to abide by this Bid for the period of One Hundred and Eighty days (180 days) from the date of Bid opening, as prescribed in Clause 14.1 of the Instructions to Bidders (Section-I), and it shall remain binding upon us and may be accepted at any time before the expiry of that period.

We confirm our Agreement to treat the Bid Document, Drawings and other records connected with the works as secret and confidential document and shall not communicate information contained therein to any other person other than the person authorized by Employer or use such information in any manner prejudicial to the safety and integrity of the works.

We undertake that, in completing for (and, if the award is made to us, in executing) the above Contract, we will observe the laws against fraud and corruption in force in India namely “Prevention of Corruption Act 1988”.

We confirm that our firm has PAN/GST registrations along with **ESI/ Workmen Compensation Policy and EPF code** as stipulated under Appendix 2 and 3 of GCC.

We hereby confirm that this Bid complies with the Eligibility, Bid validity and Bid security required as stated in the Bidding documents.

Yours faithfully,

Authorised Signature:

Name and Title of Signatory:

Name of Bidder with official seal:

Address:

5. **CONFIRMATION LETTER**

(Letterhead paper of the Contractor)

To:

[name and address of the Employer)

Dear Sir,

Subject **“Construction of Road adjacent to IOCL (L&G) Regasification Terminal Road (inside the KPL) Km:0/000 to Km:2/410” – Reg.**

We acknowledge receipt of your Letter of Award, Ref No. _____ dated _____ and unconditionally accept the offer to take up above captioned works at the price indicated in the Letter of Award.

We also confirm our acceptance to all the corrections and modifications made by the Employer in respect of our bid.

We undertake to provide you unconditional bank guarantee towards performance security and additional security for unbalanced bid as per the agreed format within the prescribed date as per the Instructions to Bidder and Conditions of Contract.

Yours faithfully,

Authorized Signature:

Name and Title of Signatory:

Name of Agency:

06. BANK GUARANTEE FOR EMD / BID SECURITY

WHEREAS _____ (Name of the Bidder) (hereinafter called the Contractor) wishes to submit his tender for “**Construction of Road adjacent to IOCL (L&G) Regasification Terminal Road (inside the KPL) Km:0/000 to Km:2/410**” herein after called “the Tender” KNOW ALL MEN by these present that we _____ (Name of Bank) _____ having our Registered Office at _____ (hereinafter called the ‘Bank’) are bound unto M/s Tamil Nadu Road Development Company Limited (TNRDC) (hereinafter called “the Employer”) the sum _____ of Rs. _____ (Rupees _____) for which payment can truly be made to the said Employer. The Bank bind themselves, their successors and assigns by these presents with the common seal of the Bank this day _____ of 2018 and undertake to pay the amount of _____ (Rupees _____) to the employer upon receipt of a written demand and without demur and without the employer having to substantiate his demand.

The conditions of this obligation are:

If the Tenderer withdraws his tender during the period of Tender validity specified in the Form of Tender Or

If the Tenderer having been notified of the acceptance of his Tender by the Employer during the period of tender validity Or

If the Tenderer fails or refuses to execute the Form of Agreement in accordance with the Instructions to Bidders, if required Or

Fails or refuses to furnish the Performance Security, in accordance with the Instruction to Bidders.

We undertake to pay the employer up to the above amount upon receipt of his first written demand and without demur and without the employer having to substantiate his demand, provided that in his demand the Employer will note that the amount claimed by him is due to the occurrence of any one of the above conditions, specifying the occurred condition or conditions.

This guarantee will remain in force up to -----(Date) and including the date 28 days beyond the validity of the bid as such deadline is stated in the Instructions to Bidders or as it may be extended by the Employer, at any time prior to the closing date for submission of the Tender Notice of which extension to the Bank is hereby waived. Any demand in respect of this guarantee should reach the Bank not later than the above date of expiry of this guarantee.

Notwithstanding anything contained herein.

- i) Our liability under this Guarantee shall not exceed the guaranteed amount **Rs. -----**
-----/- (Rupees -----only)

This Guarantee shall be valid upto -----20__ (Expiry date) and

- ii) We shall be liable to pay the guaranteed amount under this guarantee only and if we receive a written claim or demand duly signed by a duly Authorised official of the Employer before the -----20__ (Expiry date) as mentioned above.

SIGNATURE OF AUTHORISED REPRESENTATIVE OF THE BANK _____

NAME AND DESIGNATION _____

SEAL OF THE BANK _____

SIGNATURE OF THE WITNESS _____

NAME OF THE WITNESS _____

ADDRESS OF THE WITNESS _____

7. BANK GUARANTEE FOR PERFORMANCE SECURITY

BG No dated20__

To

Tamil Nadu Road Development Company Ltd.,
171, 2nd Floor, Tamil Nadu Maritime Board Building,
South Kesavaperumal Puram,
Pasumpon Muthuramalingam Road (Greenways Road),
Raja Annamalai Puram, Chennai – 600 028

Bank Guarantee No.datedfor **Rs./- (Rupees
.....only)**

WHEREAS vide the Letter Of Award (LOA) / Work order no..... dated
for **“Construction of Road adjacent to IOCL (L&G) Regasification Terminal Road (inside the
KPL) Km:0/000 to Km:2/410”** (hereinafter referred to as **“The Contract”**)
M/s....., a company incorporated under the Companies Act, 1956,
having its registered office
at..... (address)
(hereinafter referred to as **“The Contractor”** which expression shall unless repugnant to or
inconsistent with the context mean and include its successors and assigns) has been awarded by
M/s Tamil Nadu Road Development Company Ltd, a company incorporated under the
Companies Act, 1956, having its Registered office at No. 171, 2nd Floor, Tamil Nadu Maritime
Board Building, South Kesavaperumal Puram, Pasumpon Muthuramalingam Road (Greenways
Road), Raja Annamalai Puram, Chennai – 600 028 (hereinafter referred to as **“The Employer”**
which expression shall unless repugnant to or inconsistent with the context mean include its
successors and assigns), the contract for **“Construction of Road adjacent to IOCL (L&G)
Regasification Terminal Road (inside the KPL) Km:0/000 to Km:2/410”**

AND WHEREAS it has been stipulated by you in the said contract that the Contractor shall furnish
you a Performance Guarantee, within 7 days of receipt of the Letter of Award / Work order by a
specified Scheduled / Nationalised Bank, for the sum specified therein as security for compliance
with the contractor’s obligations in accordance with the Contract and against any breach or non-
performance of the terms and conditions contained in the contract.

AND WHEREAS we**BANK**, having its Head Office atand amongst
others, a branch office situated at....., have agreed to furnish a Performance Guarantee for a
sum of **Rs. -----/- (Rupees -----only)** (hereinafter referred as the
Guaranteed amount) as security for compliance of the contractor’s obligations under the contract.

NOW THEREFORE we hereby affirm that we as the Guarantor are responsible to you on behalf of
the Contractor, for the guaranteed amount and we irrevocably undertake to pay you upon your first
written demand and without demur or argument, any sum or sums within the limits of the guaranteed
amount as aforesaid without your needing to prove or to show grounds or reasons for your demand
for the sum specified herein. The guaranteed amount shall be payable merely on demand by the
Employer. Any letter stating that the amount claimed in the demand notice/letter is due and
payable, signed by a duly authorized official of the Employer to this effect, shall be final, binding or
conclusive upon us.

We, hereby agree to pay on demand the guaranteed amount without demur by crediting to the Bank Account of the Employer, the details of which are to be informed to us by you during the validity of the guarantee.

Our liability under this Guarantee shall not be affected by any change in the constitution of the Contractor or of the Guarantor.

We hereby undertake that this Guarantee is absolute, irrevocable and unconditional and shall be enforceable against us notwithstanding any security or securities comprised in any instrument executed or to be executed by the contractor in favour of the Employer.

We hereby also agree that this guarantee shall not be wholly or partially satisfied or exhausted by any payments made to or settled with the Employer by the Contractor and shall be valid and binding on us and operative until the expiry of this Guarantee.

We, further agree that no change or addition to or other modification of the terms of the contract or of the works to be performed there under or of any of the contract documents which may be made between you and the Contractor shall in any way release us from any liability under this guarantee, and we hereby waive notice of any such change, addition or modification.

The jurisdiction in relation to this Guarantee shall be Courts at Chennai and Laws of India shall be applicable. This guarantee shall be valid up to -----20__ (hereinafter referred to us as the "Expiry Date") **58 Months** from the date of Bank Guarantee or **03 months** beyond the defect liability period whichever is later.

Notwithstanding anything contained herein.

iii) Our liability under this Guarantee shall not exceed the guaranteed amount **Rs _____/- (Rupees _____ only)**

This Bank Guarantee shall be valid up to -----20__ (Expiry date) and

iv) We shall be liable to pay the guaranteed amount under this guarantee only and if we receive a written claim or demand duly signed by a duly Authorised official of the Employer before the -----20__ (Expiry date) as mentioned above.

IN WITNESS WHEREOF we have executed this guarantee on this20__.

Signature of Authorised Representative of the Bank

Name and Designation

Seal of the Bank

Signature of Witness

Name of Witness

ANNEXURE – I

MAJOR ITEMS OF CONSTRUCTIONAL PLANT

**MINIMUM MANDATORY REQUIREMENT OF PLANT AND EQUIPMENT FOR
THIS WORK**

(Proof of Ownership must be enclosed)

(Specified by Employer)

| | | |
|--|---|-------|
| 1) Concrete Batching Plant | - | 1 No |
| 2) Static Roller | - | 1 No |
| 3) Soil Compactor | - | 1 No |
| 4) Screed Vibrator | - | 2 Nos |
| 5) Needle Vibrator | - | 3 Nos |
| 6) Paver (Concrete) | - | 1 No. |
| 7) Tandem Roller | - | 1 No. |
| 8) Concrete trucks fitted with Transit Mixer | - | 5 nos |

SIGNATURE OF CONTRACTOR
CONTRACTOR CODE

ANNEXURE – II (A)

MINIMUM QUALIFICATION OF TECHNICAL PERSONNEL REQUIRED

| Sl.No | Designation | Educational Qualification | Professional Experience in similar capacity | Minimum Requirement of Personnel |
|-------|------------------------------|------------------------------|---|----------------------------------|
| 1 | Structural/Pavement Engineer | Degree in Civil Engineering | 5 Years | 1 No |
| 2 | Highway Engineer | Degree in Civil Engineering | 5 Years | 1 No |
| 3 | Field Engineer | Diploma in Civil Engineering | 5 Years | 1 No |
| 4 | Quantity Surveyor | Diploma in Civil Engineering | 5 Years | 1 No |
| 5 | Material Engineer | Degree in Civil Engineering | 5 Years | 1 No |

SIGNATURE OF CONTRACTOR
CONTRACTOR CODE

ANNEXURE – II (B)

DETAILS OF KEY PERSONNEL AND ADMINISTRATIVE PERSONNEL

Detail of Personnel proposed to be deployed by the applicant for this work

| Name of Person | Qualification | Designation | No. of years of experience | | Details of works carried out etc. |
|----------------|---------------|-------------|----------------------------|-------------|-----------------------------------|
| | | | Individual | In the firm | |

Technical Personnel

- 1.
- 2.
- 3.
- 4.
- 5.

Administrative Personnel

- 1.
- 2.
- 3.
- 4.
- 5.

Skilled and other workers

- 1.
- 2.
- 3.
- 4.
- 5.

SIGNATURE OF CONTRACTOR
CONTRACTOR CODE

Section III

Conditions of Contract

Section III: CONDITIONS OF CONTRACT

A. GENERAL

1. Definitions

- 1.1 Terms which are defined in the Contract Data are not also defined in the Conditions of Contract but kept their defined meanings. Capital initials are used to identify defined terms.

Activity Schedules means the priced and completed Activity Schedules forming part of the Bid.

Bill of Quantities (BOQ) means the completed Bill of Quantities attached in Appendix and forming part of this Contract.

Compensation Events are those defined in Clause 41 hereunder.

Confirmation Letter is the letter of the Contractor accepting the Letter of Award issued by the Employer.

The **Start Date** is the date of Contract Agreement

The **Contract Completion Date** is the date of completion of Contractor's Obligations under this Contract as certified by the Engineer in accordance with Clause 50.2.

The **Contract** is the contract between the Employer and the Contractor to execute and complete the Works. It consists of the documents listed in Clause 2.3 below.

The **Contract Data** defines the documents and other information which comprise the Contract.

The **Contractor** is a person or firm or corporate body who's Bid to carry out the Works has been accepted by the Employer.

The **Contractor's Bid** is the completed Bidding document submitted by the Contractor to the Employer.

The **Contract Price** is the price stated in the letter of Award and thereafter as adjusted in accordance with the provisions of the Contract.

Days are calendar days: **Months** are calendar months.

A **Defect** is any part of the works not completed in accordance with the Contract.

The **Defects Liability Period** is the period named in the Contract Data and calculated from the date of issue of completion certificate for the construction of Construction works (or) Construction works completion date, whichever is later.

The **Employer** is the party who will employ the Contractor to carry out the Works and in this case the employer is TNRDC, RA Puram, Chennai – 600028.

The **Engineer** is the person named in the Contract Data (or any other competent Person appointed and notified to the Contractor by the Employer to act in replacement of the Engineer) who is responsible for supervising the execution of the works and administering the Contract and in this case it is TNRDC, RA Puram, Chennai – 600028.

“Engineer Representative” means a person appointed from time to time by the Engineer under Sub-clause 5.1.

Equipment is the Contractor’s plant / machineries and vehicles brought temporarily to the site to construct the works.

Construction Works means **“Construction of Road adjacent to IOCL (L&G) Regasification Terminal Road (inside the KPL) Km:0/000 to Km:2/410”**

The **Initial Contract price** is the Works Contract price in the Employer’s Letter of Award.

The **Intended Completion Date** is the date on which it is intended that the Contractor shall complete the Construction Works or Improvement Works or both, as the case may be. The Intended Completion Date is specified in the Contract Data. The Intended Completion Date may be revised only by the Engineer by issuing an extension of time, in writing.

Letter of Award is the letter issued by the Employer to the Contractor containing the Initial Contract Price and other details as enclosed in Appendix of this Contract.

Materials are all supplies, including consumables, used by the contractor for incorporation in the Works.

Plant is any Integral part of the Works which is to have a mechanical, electrical, electronic or chemical or biological function.

Project Facility means the stretch of the Road as mentioned in Contract Data, all appurtenances thereto, including road furniture, Sign boards and other road components and all access roads up to 50m from the Project Road.

The **Site** is the area defined as such in the Contract Data.

Site Investigation Reports are those which are included in the Bidding documents and are factual interpretative reports about surface and Sub - surface conditions at the site.

Specification means the Specification of the Works included in the Contract and any Modification or addition made approved by the Engineer in writing.

Temporary Works are works designed, constructed, installed, and removed by the Contractor which are needed for construction or installation of the Works.

A **Variation** is an instruction given by the Engineer/ Employer in writing which varies the Works.

The **Works** are what the Contract requires the Contractor to carry out as part of this Contract and shall refer to Construction Works or Improvement Works or Maintenance Works or any combination thereof.

The **Works Completion Date** is the actual date of completion of the Works as certified by the Engineer in accordance with Clause 50

2. Interpretation

- 2.1 In interpreting these Conditions of Contract, singular also means plural, male also means female or neuter, and the other way around. Heading have no significance. Words have their normal meaning under the language of the Contract unless specifically defined. The Engineer will provide instructions clarifying queries about the Conditions of Contract.

- 2.2 If sectional completion is specified in the Contract data, reference in the Conditions of Contract to the Works, the Completion Date, and the Intended Completion Date apply to any Section of the works (other than references to the Completion Date and Intended Completion date for the whole of the Works).
- 2.3 The documents forming the Contract shall be interpreted in the following order of priority:
- a. Contract Agreement
 - b. Conditions of Contract including Special Conditions of Contract
 - c. Instructions to Bidders
 - d. Contract Data
 - e. Letter of Financial bid and Negotiation letter
 - f. Bill of Quantities
 - g. Letter of Award, Confirmation Letter
 - h. Performance security
 - i. Specifications and Drawings
 - j. Any other document listed in the Contract Data / bid document as forming part of the Contract (Minutes of Pre-Bid meeting, addendum and clarifications).

3. Language and Law

- 3.1 The language of the Contract and the law governing the Contract are stated in the Contract Data.

4. Engineer's Decisions

- 4.1 Except where otherwise specifically stated, the Engineer will decide contractual matters between the Employer and the Contractors in his role representing the Employer.

5. Delegation

- 5.1 The Engineer may delegate any of his duties and responsibilities to other person/organization after notifying the Contractor.

6. Communications

- 6.1 Communication between parties which are referred to in the conditions are effective only when in writing. A notice shall be effective when it is delivered (in terms of Indian Contract Act).

7. Sub-contracting

- 7.1 The contractor shall not, with out the prior consent of the Employer assign the contract or any part thereof to any other party or any benefit or interest therein or there under.

The contractor shall not sub contract the works. Except where otherwise provided by the contract, the contractor shall not sub contract any part of the works, without the prior consent of the Employer. Any such consent shall not relieve the contractor from any liability or obligation under the contract and he shall be responsible for the acts, defaults and neglects of any Subcontractor, his agents, servants or workmen as fully as if they were the acts, defaults or neglects of the contractor, his agents, servants or workmen.

Provided that the contractor shall not be required to obtain such consent from the Employer for:

- a. The provision of labour and
- b. The purchase of materials which are in accordance with the Specifications and quality standards specified in the Contract.

8. Other Contractors

- 8.1 The Contractor shall cooperate and share with the other contractors, public authorities, utilities, and the Employer and his representative between the dates given in the Schedule of the other contractors. The Contractor shall also provide facilities and services to them as may be necessary for smooth coordination. The Employer may modify the schedule of other contractors and shall notify the Contractor of any such modification.
- 8.2 Pursuant to 8.1, the Contractor hereby agrees and acknowledges that the Employer is well within their right to appoint other contractor for “**Construction of Road adjacent to IOCL (L&G) Regasification Terminal Road (inside the KPL) Km:0/000 to Km:2/410**” and any other works that the Employer may decide. The Contractor acknowledges that the Employer has no liability what so ever towards the Contractor in this regard and that the Contractor will, Unconditionally and without any financial charge, extend all necessary assistance and cooperation to the Employer and other Contractor(s), so as to ensure that the Works are completed as stipulated in the Contract Data.
- 8.3 Any default in the above regard shall be treated as a fundamental breach of the contract in terms of Clause 54.2

9. Personnel

- 9.1 The Contractor shall employ atleast 25% of certified skilled personnel out of total required personnel to carry out the functions stated in the approved program in terms of Clause 25.
- 9.2 If the Engineer asks the Contractor to remove a person who is a member of the Contractor’s staff or his work force stating reasons, the Contractor shall ensure that the person leaves the site within seven days and has no further connection with the work in the Contract.

9.3 Labour Statutory requirement

The Contractor shall confirm to and comply with the regulations and by-laws of the State or Central Government and other statutory Body the provisions contained in the various Acts specified in Appendix 2 of this section.

The Minimum requirement of the Personnel for the project is as follows:

| SI.No | Designation | Educational Qualification | Professional Experience in similar capacity | Minimum Requirement of Personnel |
|-------|------------------------------|-----------------------------|---|----------------------------------|
| 1 | Structural/Pavement Engineer | Degree in Civil Engineering | 5 Years | 1 No |

| | | | | |
|---|-------------------|------------------------------|---------|------|
| 2 | Highway Engineer | Degree in Civil Engineering | 5 Years | 1 No |
| 3 | Field Engineer | Diploma in Civil Engineering | 5 Years | 1 No |
| 4 | Quantity Surveyor | Diploma in Civil Engineering | 5 Years | 1 No |
| 5 | Material Engineer | Degree in Civil Engineering | 5 Years | 1 No |

All other necessary inputs of man power such as support staffs, field technical staffs, office staffs other than the above as deemed necessary shall be provided by the bidder within the quoted amount to ensure that the entire work is completed in accordance with the conditions stipulated herein.

10. Employer's and Contractor's Risks

10.1 The Employer carries the risks which this Contract states are Employer's risks, and the Contractor carries the risks which this Contract states are Contractor's risks.

11. Employer's Risks

11.1 The Employer is responsible for the expected risks which are in so far as they directly affect the execution of the Works in the Employer's country, the risks of war, hostilities, invasion, act of foreign enemies, rebellion, revolution, Insurrection or military or usurped power, civil war, (unless restricted to the Contractor's employees), and contamination from any nuclear fuel or nuclear waste or radioactive toxic explosive.

12. Contractor's Risks

12.1 All risks of loss or damage to physical property or personal injury and death which arise during and in consequence of the performance of the Contract other than the expected Employer's risks are the responsibility of the Contractor.

13. Insurance

13.1 The Contractor shall provide, in the joint names of the Employer and the Contractor, insurance cover from the start Date to the end of the Defects liability period, in the Amounts and deductibles stated in the Contract Data for the following events:

- a. loss of or damage to Works, Plant and Materials:
- b. loss of or damage to Equipment;
- c. loss of or damage of property (except the Works, Plant, Materials and Equipment) in connection with the Contract;
- d. personal injury or death of employer/employee personal and third party persons;

However, it is for the contractor to decide whether the minimum amount specified in the Contract data is sufficient, and if he considers it necessary, to insure for a greater amount. The policy should cover an unlimited number of claims in any one year.

- 13.2 Policies and certificates for insurance shall be delivered by the Contractor to the Engineer for the Engineer's approval before the start Date. All such insurance shall provide for compensation to be payable in the type and proportions of currencies required to rectify the loss or damage incurred. The contractor shall be responsible for effecting change to the policies and certificates as may be directed by the Engineer, within time period indicated by the Engineer.
- 13.3 If the Contractor does not provide the policies and certificates as required, the Employer may effect the insurance which the Contractor should have provided and recover the premiums the Employer has paid, from payments otherwise due to the Contractor or, if no payment is due, the payment of the premiums shall be a debt due and if warranted, recovered by invoking Performance Security.
- 13.4 Alterations to the terms of insurance shall not be made without the approval of the Engineer.
- 13.5 Both parties shall comply with any conditions of the insurance policies.
- 13.6 The Contractor shall be entitled to place all insurance relating to the Contract with insurers from India, which have been determined to be acceptable to the Employer.

14. Queries about the Contract Data

- 14.1 The Engineer will clarify queries on the Contract Data.

15. Contractor to undertake the Works

- 15.1 The Contractor shall undertake the Works in accordance with the Specifications, Conditions of Contract, Contract data, Drawings, and as per the instructions of the Engineer.

16 The Construction Works to be Completed by the Intended Completion Date

- 16.1 The contractor shall commence execution of the construction works on the start date and shall carry out the construction works in accordance with the construction program submitted by the contractor, as updated with the approval of the Engineer and complete them in all respects by the Intended Completion date. In case, if there is any delay for demolition of any structure/shifting of utilities/delay in handing over of the lands due to Land Acquisition shall be given towards the same.
- 16.2 All the time during the construction period, Contractor shall notify the Engineer details of drawings and instructions required and of why and by when it is required. This notice shall be given by the contractor at least one month advance correlating the approved construction program.

17.0 Approval by the Engineer

- 17.1 The Contractor shall submit Specifications and Drawings showing the proposed Temporary Works to the Engineer, who is to approve them if they comply with the Specifications and Drawings.
- 17.2 The Contractor shall be responsible for design of Temporary Works.

- 17.3 The Engineer's approval shall not alter the Contractor's responsibility for the quality, safety and design of the Temporary Works, who shall bear all consequences of failures thereof.
- 17.4 The Contractor shall obtain approval of other parties/ agencies to the design of the Temporary Works where required.
- 17.5 All Drawings prepared by the Contractor for the execution of the temporary or permanent works are subject to prior approval by the Engineer before their use.

18.0 Safety

- 18.1 The contractor shall be responsible for the safety of all activities on the Site. The proposed work site falls in High speed road Corridor. In addition to the safety of workmen in the project, the Contractor is responsible for the safety of the road users. The Contractor shall at his own cost formulate and implement an efficient traffic movement/regulation plan so as to achieve safe and efficient movement of vehicular traffic and pedestrians.
- 18.2 The contractor shall make necessary safety arrangements and equipments specified in Appendix 1 of this section.
- 18.3 Any damage caused to the existing structure, the road surface and other appurtenances shall be remedied /restored /replaced to the original condition at the cost of the Contractor and to the satisfaction of the Employer.
- 18.4 In case of default by the contractor, the Employer has the option to carry out the required remedial/restoration/replacement works and deduct the expenditure incurred from the payments due to the Contractor.
- The Contractor shall take all reasonable steps to protect the environment on and off the Site and to avoid damage or nuisance to persons or to property of the public or others resulting from pollution, noise or other causes arising as a consequence of his methods of operation.
- 18.5 During continuance of the contract, the Contractor shall abide at all times by all existing enactments on environments on environmental protection and rules, labour laws made there under, regulations, notifications and bye-laws of the State or Central Government, or local bodies/authorities and any other law, bye-law, regulations that may be passes or notification that may be issued in this respect in future by the State or Central Government or the local authority.
- 18.6 Salient features of some of the major statutory laws (Acts) that are applicable are given below:

The Water (Prevention and Control of Pollution) Act, 1974, provides for the prevention and control of water pollution and the maintaining and restoring of wholesomeness of Water. 'Pollution' means such contamination of water or such alteration of the physical, chemical or biological properties of water or such discharge of any sewage or trade effluent or of any other liquid, gaseous or solid substance into water (whether directly or indirectly) as may, or is likely to, create a nuisance or render such water harmful or injurious to public health or safety, or to domestic, commercial, industrial, agricultural or other legitimate uses, or to the life and health of animals or plants or of aquatic organisms.

The Air (Prevention and Control of Pollution) Act, 1981, provides for prevention, control and abatement of air pollution. 'Air Pollution' means the presence in the atmosphere of any 'air pollutant', which means any solid, liquid or gaseous substance (including noise) present in the atmosphere in such concentration as may be or tend to be injurious to human beings or other living creatures or plants or property or environment.

The Environment (Protection) Act, 1986, provides for the protection and improvement of environment and for matters connected therewith, and the prevention of hazards to human beings, other living creatures, plants and property. 'Environment' includes water, air and land and the inter-relationship which exists among and between water, air and land, and human beings, other living creatures, plants, micro-organism and property.

The Public Liability Insurance Act, 1991, provides for public liability insurance for the purpose of providing immediate relief to the persons affected by accident occurring while handling hazardous substances and for matters connected herewith or incidental thereto. Hazardous substance means any substance or preparation which is defined as hazardous substance under the Environment (Protection) Act 1986, and exceeding such quantity as may be specified by notification by the Central Government.

19.0 Discoveries

- 19.1 Anything of historical or other interest or of significant value unexpectedly discovered on the Site is the property of the Employer. The Contractor is to notify the Engineer/ Employer of such discoveries and carry out the Engineer's instructions for dealing with them.

20.0 Possession of the Site

- 20.1 The Employer shall give possession of the site to the Contractor in accordance with the Contract Data. If possession of a part is not given by the agreed date stated in the Contract Data, then the Intended Completion Date shall be postponed by the Employer as may be required for that particular part/ stretch. However, this will not be applicable if sufficient work site is made available to the Contractor as and when required, for him to proceed ahead with the progress of work and if available work fronts remain unattended.
- 20.2 The Contractor will co-ordinate with service provider/ concerned authorities for shifting of utilities and removal of encroachments etc. and making the site unencumbered from the project construction area required for completion of work. This includes getting estimates, initial and frequent follow-up with concern authorities. However, the cost of shifting shall be borne by the employer. The contractor will not be entitled for any additional compensation for delay in shifting of utilities and removal of encroachments by the service provider/ local bodies/concern authorities.

21.0 Access to the Site

- 21.1 The Contractor shall allow the Engineer and any person authorized by the Engineer access to the Site, to any place where work in connection with the Contract is being carried out or is intended to be carried out and to any place where materials or plant are being manufactured / fabricated / tested/ stored for the works.

22.0 Instructions

- 22.1 The Contractor shall carry out all instructions of the Engineer which comply with the applicable laws where the Site is located.

23.0 Disputes

- 23.1 If either party believes that a decision taken by the Employer was either outside the authority given to the Employer by the contract or that the decision was wrongly taken, the objecting party may file written notice of dispute to the other party with a copy to the Engineer stating that it is giving the notice pursuant to this Clause while stating clearly the basis for the dispute.

- 23.2 The party receiving the dispute notice will consider it and reply in writing within 30 days of the receipt of the notice. If no reply is received or the reply is not acceptable to the other party, the affected party may refer only to the High Court of Madras (Chennai) for adjudication.
- 23.3 Further, in case of any dispute or difference between the parties to the contract after the completion of the works or after the determination / abandonment of the contract or any other matter/s arising thereof shall be referred to or filed with the High Court of Madras (Chennai) within a period of **18 Months** beyond such date. No other courts or persons or bodies will have any jurisdiction over the dispute/s beyond such date.
- 24.0 Deleted

B. Time Control

25.0 Program

- 25.1 The Contractor should adhere to the construction programme submitted by the contractor and approved by the Engineer and complete the works within the agreement time without any lapse.

26.0 Extension of the Intended Completion Date for Construction Works

- 26.1 The Engineer shall extend in consultation with Employer the Intended Completion Date if a Compensation Event occurs or a Variation is issued which makes it impossible for Completion to be achieved by the Intended Completion Date without the Contractor taking steps to accelerate the remaining work and which would cause the Contractor to incur additional cost.
- 26.2 The Engineer shall decide whether and by how much to extend the Intended Completion Date within 21 days of the Contractor asking the Engineer for a decision upon the effect of a Compensation Event or Variation and submitting full supporting information. If the Contractor has failed to give early warning of a delay or has failed to cooperate in dealing with a delay, the delay by this failure shall not be considered in assessing the new Intended Completion Date.
- 26.3 Major portion of land required for the construction work will be handed over to the contractor. However, if there is any delay in the process of Land Acquisition and any delay in handing over required land for the construction work extension of time alone will be considered for completion of work at no extra cost.

27 Delays Ordered by the Engineer

- 27.1 The Engineer in consultation with the Employer may instruct the Contractor to delay the start or progress of any activity within the Works.

28 Management Meetings/ Site Visits

- 28.1 Either the Engineer or the Contractor may require the other to attend a Management Meeting. The business of a Management Meeting shall be to review the programme for the remaining work and to deal with the matters regarding progress of works etc.
- 28.2 The Engineer shall record the minutes of Management Meetings and is to provide copies of his record to those attending the meeting and to the Employer. The responsibility of the parties for actions to be taken is to be decided by the Engineer either at the Management Meeting or after the Management Meeting and stated in writing to all who attended the meeting. Failure to attend the Management Meetings/ site visits shall attract penalties at the

rate indicated in the Contract Data and in case of non-attendance of more than three such meetings/ visits then the same shall be construed as fundamental breach of Contract in terms of Clause 54.

29 Early Warning

- 29.1 The Contractor is to warn the Engineer at the earliest opportunity of specific likely future events or circumstances that may adversely affect the quality of the work, increase the Contract Price or delay the execution of works. The Engineer may require the Contractor to provide an estimate of the expected effect of the future event or circumstance on the Contract Price and Completion Date. The estimate is to be provided by the Contractor as soon as reasonably possible.
- 29.2 The Contractor shall cooperate with the Engineer in making and considering proposals for how the effect of such an event or circumstance can be avoided or reduced by any one involved in the work and in carrying out any resulting instructions of the Engineer.

C. Quality Control

30 Identifying Defects

- 30.1 The Engineer shall check the Contractor's work and notify the Contractor of any Defects that are found. Such checking shall not affect the Contractor's responsibilities. The Engineer may instruct the Contractor to search for a Defect and to uncover and test any work that the Engineer considers may have a Defect.
- 30.2 The contractor shall permit the Employer's Technical auditor to check the contractor's work and notify the Engineer and Contractor of any defects that are found. Such a check shall not affect the Contractor's or the Engineer's responsibility as defined in the Contract Agreement.

31 Tests

- 31.1 The Contractor shall establish suitable Testing Facility with adequate and suitable equipment, to the satisfaction of the Engineer, in the vicinity of the Project Road or site office premises or Works Site premises. The cost of setting up the Testing Facility and testing there to, shall be to the account of the Contractor. If the Engineer instructs the Contractor to carry out a test not specified in the Specification to check whether any work has a Defect and the test shows that it does, the Contractor shall pay for the test and any samples.

32 Correction of Defects

- 32.1 The Engineer shall give notice to the Contractor of any Defects before the end of the Defects Liability Period. The Defects Liability Period shall be extended for as long as Defects remain to be corrected.
- 32.2 Every time notice of a Defect is given, the Contractor shall correct the notified Defects within the length of time specified by the Engineer's notice.

33 Uncorrected Defects

- 33.1 If the Contractor has not corrected a Defect within the time specified in the Engineer's notice, the Engineer will assess the cost of having the Defect corrected and rectify the defects if needed, by employing other persons and the Contractor will pay this amount or can be recovered from the bills of the contractor.

D. Cost Control

34 Bill of Quantities (BOQ)

- 34.1 The Bill of Quantities for works contains items for the Works being implemented by the Contractor as in Section – V.
- 34.2 The Bill of Quantities is used to calculate the payment for works. The Contractor will be paid for the quantity of the work done at the rate in the Bill of Quantities for each item of work.

35 Changes in the Quantities

- 35.1 Any additional quantity required for completing the work will have to be carried out by the Contractor at the same quoted rate. There will be no percentage ceiling either on addition or reduction in the quantities for completion of the project.
- 35.2 Provided further that no change in the rate or price for any item contained in the Contract shall be considered unless such item accounts for an amount more than **2%** of the Contract Price, and the actual quantity of work executed under the item exceeds or falls short of the quantity set out in the Bill of Quantities by more than **25%** of the Contract Price.

36. Variations during Implementation of Construction Works

- 36.1 Approval and methodology for all variations either Rate or Quantity should be followed as per the directions of the Engineer / Engineers representative.

37. Payments for Variations in Construction Works

- 37.1 The Contractor shall provide the Engineer with an estimate and quotation (with break up of unit rates) along with detailed justification, vouchers, for carrying out the Variation items, **if not available in the BOQ** and when requested to do so by the Engineer. The Engineer shall assess the quotation, with in a period of 7 (seven) days of the request (or) with in a reasonable time by the Engineer, and before the variation is ordered.
- 37.2 If the work in the Variation corresponds with an item description in the Bill of Quantities and if, in the opinion of the Engineer, the timing of its execution do not cause the cost per unit of quantity to change, the rate in the Bill of Quantities shall be used to calculate the value of the Variation. If the cost per unit of quantity changes, or if the nature or timing of the work in the Variation does not correspond with items in the Bill of Quantities, the quotation by the Contractor shall be in form of new rates for the relevant items of work as per the Tamil Nadu Building Practice / National Building Code and standard procedures.

- (a) The Contractor shall submit a detailed rate analysis with all supporting documents. Such analysis shall be prepared based on similar items available in Bill of Quantities, subject to mutual Agreement between the Engineer and the Contractor and according to the MoRTH , IRC and IS specification and standard procedures adopting the schedule of rates for the current year applicable to the Chennai region of Tamil Nadu.
- (b) In case the data for the item is not available in the standard data, observed data with current schedule of rates applicable to Chennai region of Tamil Nadu shall be adopted.

With the concurrence of the employer, the Engineer shall determine the quantities and rates for the variation works. Prior approval should be obtained for all the variation items from the employer.

- 37.3 If the Contractor's quotation is unreasonable (or if the contractor fails to provide the Engineer with a quotation within a reasonable time specified by the Engineer in accordance with Clause 37.1), the Engineer shall fix the variation rate and make a change to the Contract

Price which shall be based on Engineer's own forecast of the effects of the Variation on the Contractor's costs.

37.4 If the Engineer decides that the urgency of varying the work would prevent a quotation being given and considered without delaying the work, the Engineer shall instruct in writing, to commence the additional works before the approval of the rate.

37.5 The Contractor shall not be entitled to additional payment for costs that could have been avoided by giving early warning.

38. Cash flow forecasts

The Contractor is to provide the Engineer with a cash flow forecast and an updated cash flow forecast as appropriate.

39. Payment

39.1 "The Contractor shall submit a statement in 3 (three) copies to the Engineer by the 7th (seventh) day of each month, signed by the authorized representative of the Contractor, for the work executed up to the end of the previous month in a tabulated form approved by the Engineer, showing the amounts to which the Contractor considers himself to be entitled. The statement shall include the following items, as applicable, which shall be taken into account in the sequence listed:

- (a) the estimated value of work executed (Works executed & payable) up to the end of the month in question determined in accordance with conditions of contract, at base unit rates and prices;
- (b) the Actual value certified for payment for the Temporary and Permanent Works executed up to the end of the previous month, at base unit rates and prices;
- (c) the estimated value at base unit rates and prices of the Temporary and Permanent Works for the month in question, obtained by deducting (b) from (a);
- (d) the value of any variations executed up to the end of the month in question, less the amount certified in the previous Interim Payment Certificate.
- (e) amount to be deducted for all taxes in accordance with contract conditions.
- (f) net amount of application, which will be expressed in Indian Rupees.
- (g) The details of RFI, joint measurement sheets, level sheets, test results to be enclosed along with the bill.

Notwithstanding the terms of this Sub-Clause or any other Clause of the Contract, no amount will be certified by the Engineer for payment until the Performance Security has been provided by the Contractor and approved by the Employer."

39.2 Monthly Payments

"Within 7 (seven) days of receipt of the monthly statement from the Contractor in pursuant to above, the Engineer shall broadly determine the amount due to the Contractor and shall, accordingly, recommend to the Employer for release to the Contractor up to a maximum of 70% of net payment as part payment against the monthly statement, pending certificate of IPC by the Engineer. Within 10 (ten) days of the receipt of recommendation of the Engineer, the Employer shall make payment to the Contractor.

The said statement shall be approved or amended by the Engineer in such a way that in his opinion, it reflects the amount due to the Contractor in accordance with the Contract, after

deduction, of any sums which may have become due and payable by the Contractor to the Employer. In cases where there is a difference of opinion as to the value of any item, the Engineer's view shall prevail.

Within 21 (twenty one) days of the receipt of the monthly statement referred as above, the Engineer shall carry out check measurement as required by the employer and recommend payment of balance 30% of bill, if satisfied; Engineer to account for liquidated damages and other deductions, and add/deduct amounts to account for variation in price of bitumen as the case may be, while arriving at amount payable to contractor; if not satisfied with works, Engineer to inform Employer and instruct Contractor to complete the works within a stipulated time and carry forward this balance amount;

Engineer shall determine the amount due to the Contractor and shall deliver to the Employer and the Contractor, an Interim Payment Certificate, certifying the amounts due to the Contractor after adjusting the payment already released to the Contractor against the said statement.

Employer will make payment within 10 (ten) days of receipt of payment recommendation from Engineer; and

Notwithstanding anything contained herein above, the final payment due shall be made only upon completion of Construction works, and suitable certification by the Engineer.

39.3 Retention money

In each Interim Payment Certificate (IPC) @ 5% of value of work executed during each bill will be withheld and the withheld amount will be refunded to the contractor along with the Final bill / Taking over certificate. The maximum amount of Retention money to be with held is restricted up to 5% of the contract value.

40 Delayed and Disputed Payments

40.1 The Employer shall pay the Contractor, the amounts certified by the Engineer within the periods stipulated in this Contract. If the Employer makes a late payment, the contractor shall be paid interest on the late payment along with the next payment. Interest shall be calculated from the date by which the payment should have been made up to the date when the payment is made at the rate of 8% p.a.

40.2 If an amount certified is increased either in a later certificate or as a result of any judgement, the contractor shall be paid interest upon the delayed payment as set out in this clause. Interest as referred above, shall be calculated from the date upon which the increased amount would have been accepted by the Employer in the absence of dispute.

41 Compensation Events

41.1 The following are compensation events unless they are caused by the Contractor;

- (a) The Engineer orders a delay in execution of works for a period of more than 60 days;
- (b) The effect on the Contractor of any of the Employer's Risks; and
- (c) Other Compensation Events listed in the contract data, if any.

41.2 If a Compensation Event would prevent the Works from being carried out in terms of the Contract, then the Employer shall extend the Intended Completion Date as may be warranted. The Engineer shall decide by how much the Intended Completion Date shall be extended.

- 41.3 As soon as information demonstrating the effect of each Compensation Event has been provided by the Contractor, it is to be assessed by the Engineer and the Intended Completion period shall be adjusted accordingly. If the Contractor's forecast is deemed unreasonable, the Engineer shall adjust the Intended Completion Period on Engineer's own forecast. The Engineer will assume that the Contractor will react competently and promptly to the event.
- 41.4 The Contractor shall be entitled to compensation to the extent that the Employer's interests are adversely affected by the Contractor not having given early warning or not having cooperated with the Engineer/Employer.

42. Tax

- 42.1 The rates quoted by the Contractor shall be deemed to be inclusive of the GST, sales tax, contract tax, royalty, Toll tax, cess and other taxes/duties/levies as may be levied by Central / State Governments and local bodies that the Contractor will have to pay for the performance of this Contract. The Employer will perform such duties in regard to the deduction of such taxes at source as per applicable law.
- 42.2 The contractor shall have valid Registration for GST and PAN as prescribed in Appendix 3

43. Currency

- 43.1 All payments shall be made in Indian Rupees only.

44. Price Adjustment for Works

The amounts payable to the Contractor and valued at base rates and prices in the Interim Payment Certificates issued by the Engineer, shall be adjusted in respect of the rise or fall in the index cost for labour, Contractor's Equipment, Plant, materials, and other inputs to the Works, by the addition or subtraction of the amounts determined by the formulae prescribed in this Clause.

44.1 Other Changes in Cost

To the extent that full compensation for any rise or fall in costs to the Contractor is not covered by the provisions of this or other Clauses in the Contract, the unit rates and prices included in the Contract shall be deemed to include amounts to cover the contingency of such other rise or fall of costs.

44.2 Price Adjustment Formulae

Contract Price shall be adjusted for increase or decrease in rates and price of labour, materials, fuels and lubricants in accordance with the following principles and procedures as per formula given below. The amount certified in each payment certificate is adjusted by applying the respective price adjustment factor to the payment amounts due:

- (a) Price adjustment shall apply only for work carried out within the stipulated time or extensions granted by the Employer and shall not apply to work carried out beyond the stipulated time; price adjustment for extensions for reasons attributable to the Contractor, shall be paid in accordance with the following clauses.

Price adjustment shall be calculated as per the formula given below:

- (b) Following expressions and meanings are assigned to the value of the work done during each month:

R = Total value of work done during the month. It would include the value of materials on which secured advance has been granted, if any during the month less than the value of materials in respect of which the secured advance has been recovered, if any during the month. This will exclude cost of work on items for which rates were fixed under variations for which the escalation will be regulated as mutually agreed at the time of fixation of rate.

i) Adjustment for Labour Component

Price adjustment for increase or decrease in the cost due to labour shall be paid in accordance with the following formula:

$$V_L = 0.85 \times P_l/100 \times R \times (L_i - L_o)/L_o$$

V_L = increase or decrease in the cost of work during the month under consideration due to changes in rates for local labour.

L_o = the average consumer price index for industrial workers for the place as defined in the Appendix to Bid, in the previous month prior to the closing date of submission of bids as published by Labour Bureau, Ministry of Labour, Government of India.

L_i = The average consumer price index for industrial workers for the place as defined in the Appendix to Bid, in the previous month prior to the last day of the period to which a particular Interim Payment Certificate is related as published by Labour Bureau, Ministry of Labour, Government of India.

P_l = Percentage of labour component of the work.

Note: For the application of this Clause, index of Industrial Workers has been chosen to represent the labour component.

ii) Adjustment for Cement Component

(Cement of various kind and grades as mentioned in WPI as analogous terms)

Price adjustment for increase or decrease in the cost of cement procured by the Contractor shall be paid in accordance with the following formula.

$$V_c = 0.85 \times P_c/100 \times R \times (C_i - C_o)/C_o$$

V_c = Increase or decrease in the cost of work during the month under consideration due to changes in the rates for cement

C_o = The all India average wholesale price index for cement in the previous month prior to the closing date of submission of bids as published by the Ministry of Commerce & Industry, Government of India.

C_i = The all India average wholesale price index for cement in the previous month prior to the last day of the period to which a particular Interim Payment Certificate is related, as published by Ministry of Commerce & Industry, Government of India.

P_c = Percentage of cement component of the work

(iii) Adjustment for steel component

Price adjustment for increase or decrease in the cost of steel procured by the Contractor shall be paid in accordance with the following formula:

$$V_s = 0.85 \times P_s/100 \times R \times (S_i - S_o)/S_o$$

V_s = Increase or decrease in the cost of work during the month under consideration due to changes in the rates for steel.

S_o = The all India average wholesale price index for steel (Bars and Rods) in the previous month prior to the closing date of submission of bids as published by the Ministry of Commerce & Industry, Government of India.

S_i = The all India average wholesale price index for steel (Bars and Rods) in the previous month prior to the last day of the period to which a particular Interim

Payment Certificate is related as published by the Ministry of Commerce & Industry, Government of India.

P_s = Percentage of steel component of the work

Note: For the application of this Clause, index of Bars and Rods has been chosen to represent steel component.

(iv) Adjustment for Plant and machinery and spares component

Price adjustment for increase or decrease in the cost of Plant and machinery spares procured by the Contractor shall be paid in accordance with the following formula:

$$V_p = 0.85 \times P_p/100 \times R_x (P_i - P_o)/P_o$$

V_p = Increase or decrease in the cost of work during the month under consideration due to changes in the rates for Plant and machinery spares

P_o = The all India average wholesale price index for heavy machinery and parts in the previous month prior to the closing date of submission of bids as published by the Ministry of Commerce & Industry, Government of India.

P_i = The all India average wholesale price index for heavy machinery and parts in the previous month prior to the last day of the period to which a particular Interim Payment Certificate is related as published by the Ministry of Commerce & Industry, Government of India.

P_p = Percentage of Plant and machinery spares component of the work

Note: For the application of this Clause, index of heavy machinery and parts has been chosen to represent the Plant and Machinery spares component.

(v) Adjustment for Bitumen Component (of various grades as analogous terms mentioned in WPI)

Price adjustment for increase or decrease in the cost of bitumen shall be paid in accordance with the following formula:

$$V_b = 0.85 \times P_b/100 \times R_x (B_i - B_o)/B_o$$

V_b = increase or decrease in the cost of work during the month under consideration due to changes in the rates for bitumen:

B_o = the average official retail price of bitumen at the nearest refinery for the place as defined in Appendix to Bid, in the previous month prior to the date of submission of Bids.

B_i = the average official retail price of bitumen at nearest refinery for the place as defined in Appendix to Bid, in the previous month prior to the last day of the period to which a particular Interim Payment Certificate is related.

P_b = Percentage of bitumen component of the work.

(vi) Adjustment for Fuel and Lubricants (POL)

Price adjustment for increase or decrease in the cost of POL (fuel and lubricant) shall be paid in accordance with the following formula:

$$V_f = 0.85 \times P_f/100 \times R_x (F_i - F_o)/F_o$$

V_f = Increase or decrease in the cost of work during the month under consideration due to changes in rates for fuel and lubricants.

F_o = The average official retail price of High Speed Diesel (HSD) oil at the existing consumer pumps of IOC for the place defined in the Appendix to Bid in the previous month prior to date of submission of bids.

F_i = The average official retail price of HSD at the existing consumer pumps of IOC for the place defined in the Appendix to Bid in the previous month prior to the last day

of the period to which a particular Interim Payment Certificate is related

P_f = Percentage of fuel and lubricants component of the work.

Note: For the application of this clause, the price of High Speed Diesel oil at the IOC pumps has been chosen to represent fuel and lubricants component.

- *Based price index for Industrial Workers to be published by Labour Bureau, Ministry of Labour, Govt. of India be checked.*

(vii) **Adjustment for Other Local Materials**

Price adjustment for increase or decrease in cost of local materials other than cement, steel, bitumen, plant spares and POL procured by the Contractor shall be paid in accordance with the following formula:

$$V_m = 0.85 \times P_m / 100 \times R_x (M_i - M_o) / M_o$$

V_m = Increase or decrease in the cost of work during the month under consideration due to changes in rates for local materials other than cement, steel, bitumen, plant spares and POL.

M_o = The all India average wholesale price index (all commodities) in the previous month prior to date of submission of bids, as published by the Ministry of Commerce & Industry, Government of India.

M_i = The all India average wholesale price index (all commodities) in the previous month prior to the last day of the period to which a particular Interim Payment Certificate is related as published by the Ministry of Commerce & Industry, Government of India.

P_m = Percentage of local material component (other than cement, steel, bitumen, plant spares and POL) of the work.

(viii) The following percentages will govern the price adjustment of the contract:

| | | |
|----|--|--------------------|
| 1. | Labour – P_l | 20 % |
| 2. | Plant and Machinery and Spares - P_p | 20 % |
| 3. | POL - P_f | 10 % |
| 4. | Bitumen- P_b | x % |
| 5. | Cement - P_c | y % |
| 6. | Steel - P_s | z % |
| 7. | Other materials - P_m | 50 - (x + y + z) % |
| | Total | 100 % |

(Note: x, y, z are the actual percentage of material of bitumen, cement and steel respectively used for execution of work as per the Interim Payment Certificate for the month).

44.3 Base, Current and Provisional Indices

The base cost indices or prices shall be those prevailing in the previous month prior to the closing date for submission of bids. Current indices or prices shall be those prevailing in the previous month to which a particular Interim Payment Certificate is related. If at any time, the current indices are not available, provisional indices as determined by the Engineer will be used, subject to subsequent correction of the amounts paid to the Contractor when the applicable indices become available.

44.4 Limit of Price Adjustment

Provided that, in determining all such price adjustment in accordance with the aforesaid Sub-Clauses:

- (a) No account will be taken of any amount by which any cost incurred by the Contractor has been increased by default or negligence of the Contractor.
- (b) If the Contractor fails to complete the work within time for completion, the adjustment of prices thereafter until the completion of the works shall be made using either the indices or prices relating to prescribed time for completion, or the current indices or prices, whichever is more favourable to the Employer, provided that if an extension of time is granted, the above position shall apply to the adjustments made after expiry of such extension of time.

44.5 Subsequent Legislation

If, after the date 28 days prior to the latest date for submission of tenders for the Contract, there occur changes to any National or State Statute, Ordinance, Decree or other Law or any regulation or bye-law of any local or other duly constituted authority, or the introduction of any such State Statute, Ordinance, Decree, Law, regulation or bye-law which causes additional or reduced cost to the Contractor, other than under the preceding Sub-Clauses of this Clause, in the execution of the Contract, such additional or reduced cost shall, after due consultation with the Employer and the Contractor, be determined by the Engineer and shall be added to or deducted from the Contract Price and the Engineer shall notify the Contractor accordingly, with a copy to the Employer.

Notwithstanding the foregoing, such additional or reduced cost, shall not be separately paid or credited if the same shall already have taken into account in the indexing of any inputs to the Price Adjustment Formulae in accordance with the provisions of Sub-Clause (1) to (5) of this Clause.

45. Penalty and Liquidated Damages

45.1 For Construction Works

- (a) In case of non-completion of the construction works within the Intended Completion Date, the Contractor shall pay liquidated damages to the Employer at the rate specified in contract data for each day that the actual completion date is later than the intended completion date. The liquidated damages amount shall be deducted from payments due to the Contractor and shall not be refundable. The total amount of liquidated damages shall not exceed the amount defined in the Contract Data.
- (b) Time is the essence of the Contract and payment or deduction of penalty or liquidated damages shall not relieve the Contractor from his obligation to complete the works as per agreed Construction Program or from any of the other Contractor's obligations and liabilities under the Contract or the Employer's right to invoke the Performance Security.
- (c) In case of default performance on the part of the contractor to engage required personnel for the work as stipulated in Clause 9.3, a penalty of **Rs.20,000/-** per month for the Diploma holder and **Rs.30,000/-** per month for the Degree holder shall be levied based on the norms for the value of this contract.

45.2 For Maintenance Works

In case the Contractor has not rectified or addressed deficiencies as directed by the Engineer at the time of Site inspections during defects liability period, the Employer retains the right to get works done through a third party and debit the cost and expenses incurred to the Contractor. Alternatively, the Engineer may recommend invoking of Performance

Security in part or full, as the case may be. In case the Contractor still fails to rectify or address deficiencies even after invoking Performance Security, as described earlier, then the Employer shall treat the event as fundamental breach of Contract in terms of Clause 54 of Conditions of Contract.

46. Deleted

47. Advance Payment for Construction Works

47.1 No Mobilisation advance/Machinery and equipment advance payment will be made to the Contractor for the works.

47.2 No material advance will be made or paid to the Contractor.

48. Securities

48.1 The Performance Security (including additional security for unbalanced bids) shall be provided to the Employer not later than the date specified in the Letter of Award and shall be issued in an amount and form indicated in Contract Data from:

- a. State Bank of India or subsidiaries;
- b. Any Indian Nationalised Bank; or
- c. Any Scheduled Bank

as acceptable to the Employer, and denominated in Indian Rupees. The Performance Security shall be valid for period of **58 Months**. If the performance security is in the form of Bank Guarantee, the same shall be valid for a period of **58 months** from the date of Bank Guarantee or **03 months** beyond the Defect Liability period whichever is later. In case the Intended Completion Date is extended, then the Contractor shall submit a fresh Performance Security or extension of the date of the Bank Guarantee/s if any, furnished as security, the same value valid up to a date one month beyond the issue of Defect Liability Certificate.

49. Cost of Repairs

49.1 Loss or damage to or defective works or Materials during the Contract Period shall be remedied by the Contractor at the Contractor's cost to the satisfaction of the Engineer/Employer. In case of default by the Contractor, the Employer shall carry out suitable remedial measures and deduct the amount incurred thereto from payments due to the Contractor.

E. Finishing the Contract

50. Completion

50.1 The Contractor shall request the Engineer to issue a Certificate of Completion of Works and the Engineer will do so upon deciding that the Works are completed in all respects.

50.2 Upon satisfactory compliance and observance of the performance standards by the Contractor during the Defect Liability Period, the Engineer shall suitably inform the Employer who may then issue the Certificate of Contract Completion to the Contractor, Subject to Contractor satisfying all Provisions under this Contract.

51 Taking Over

51.1 The Employer will take over the Site and the Works with in 1 month of the Engineer issuing a certificate of Contract Completion in terms of Clause 50.2.

52 Final Account

52.1 In case of Construction Works, the Contractor shall supply to the Engineer a Detailed account of the total amount that the contractor considers payable under the Contract on or before 30 days beyond the Engineer shall assess the quality and completion status of Construction Works in terms of this Contract and upon satisfaction, shall certify and final payment that is due to the contractor within 30 days of receiving the Contractor's account. If the Engineer is not satisfied, then the Engineer shall issue within 7 days thereto, a schedule that states the scope of the corrections or additions that are necessary. If the Contractor fails to comply with the Engineer's instructions. The Engineer shall levy Liquidated Damages and shall recommend the Employer suitably. The Employer retains the right to employ a third party and carry out the remaining works and deduct the payment from pending bills of the Contractor.

53 As Built Drawings, Operating and Maintenance Manuals

53.1 "As Built" Drawings and Operation and Maintenance Manuals as required by the Employer shall be supplied by the Contractor as stated in the Contract Data.

53.2 If the Contractor does not supply the Drawings and/or manuals as stated in the Contract Data, or they do not receive the Engineer's approval, the Engineer shall withhold the amount stated in the Contract Data from payments due to the Contractor.

54. Termination

54.1 The Employer or the Contractor may terminate the contract if the other party causes a fundamental breach of the Contract.

54.2 Fundamental breach of Contract includes, but shall not be limited to the following:

- (a) Contractor stops work for 28 days when no stoppage of work is shown on the agreed program and the stoppage has not been authorized by the Employer.
- (b) Employer or the Contractor is made bankrupt or goes into liquidation, other than for a reconstruction or amalgamation
- (c) Payment certified by the Engineer is not paid by the Employer to the Contractor within 60 days of the Engineer's Certificate.
- (d) The Engineer gives Notice that failure to correct a particular Defect is a fundamental breach of Contract and the Contractor fails to correct it within a reasonable period of time determined by the Engineer;
- (e) The Contractor does not maintain a security (performance security, Security against Advance Payment etc) which is required;
- (f) In case of the Contractor has awarded more than 20% of value of works on sub-contract
- (g) The Contractor has defaulted in fulfilling his obligations under this Contract;
- (h) The Contractor has contravened clause 7,8 and 9 of the conditions of contract
- (i) The Contractor does not adhere to the agreed construction program of individual milestone and also fails to take Satisfactory remedial action as per agreements reached in the Management Meetings (clause 28) for a period of 30 days;
- (j) The Contractor fails to carry out the instructions of Engineer within a reasonable time determined by the Engineer in accordance with Clause 15.1 and 22.1 of the conditions of Contract.

- (k) The Contractor has delayed the completion of works by the number of days for which the maximum amount of liquidated damages can be paid as defined in the Contract Data; and
- (l) If the Contractor, in the judgment of the Employer has engaged in corrupt or fraudulent practices in competing for or in the executing the Contract.

For the purpose of this paragraph “corrupt practice” means the offering, giving, receiving or soliciting anything of value, to influence the action of a public official or the Employer or Engineer in the procurement process or in contract execution. “Fraudulent practice” means a misrepresentation of facts in order to influence a procurement process or the execution of a contract, and includes collusive practice among Contractors (prior to or after bid submission) designed to establish bid prices at artificial non competitive levels and to deprive the Employer if the benefits of the free and open competition.”

- 54.3 When either party to the Contract gives notice of a breach of Contract to the Engineer for a cause than those listed under Clause 54.2 above, the Engineer shall decide whether the breach is fundamental or not.
- 54.4 Notwithstanding the above, the Employer may terminate the Contract for his convenience.
- 54.5 If the Contract so terminated the Contractor shall stop work immediately make the site safe and secure and leave the site as soon as reasonably possible.
- 54.6 In case the Contractor fails to carryout the works, as per the construction programme submitted by the Contractor and approved by the Engineer then the Employer, at its sole discretion is entitled to terminate this contract at the ‘**Risk and Cost**’ of the Contractor and to employ such other Contractor/s to carryout the balance works. The additional cost incurred by the employer in completing the works, which remain unfinished at the time of termination of the contract will be recovered from the Contractor. Any unrecovered ‘Risk and Cost’ amount will be a debt payable to the Employer and the Employer will take suitable actions for such unrecovered ‘Risk and Cost’ amount at the cost of the Contractor. Any bill/s for the works executed remains unsettled and/or the value of materials, machineries etc., taken over or possessed by the Employer at the time of termination or on termination will be adjusted towards the ‘Risk and Cost’ recoverable from the contractor.

55. Payment upon Termination

If the Contract is terminated because of fundamental breach of Contract by the Contractor, the Engineer shall issue a certificate for the value of the work done less advance payment received up to the date of the issue of the work certificate, less other recoveries due in the terms of the Contract, less taxes due to be deducted at source as per applicable law and the estimated/actual ‘**Risk and Cost**’ to be recovered from the contractor due to termination. If the total amount due to the Employer exceeds any payment due to the Contractor the difference shall be a debt payable to the Employer.

If the Contract is terminated at the Employer’s convenience or because of a fundamental breach of Contract by the Employer, the Engineer shall issue a certificate for the value of the Works done, the reasonable cost removal of Equipment, repatriation of the Contractor’s personnel employed solely on the Works, and the Contractor’s cost of protecting and securing the Works and less advance payments received up to the date of the certificate, less other recoveries due in terms of the contract and less taxes due to be deducted at source as per applicable law.

56 Property

- 56.1 All materials on the site, plant, Equipment, Temporary Works and Works are deemed to be property of the Employer, if the Contract is terminated because of a Contractor’s default.

57. Release from Performance

- 57.1 If the Contractor is frustrated by the outbreak of war or by any other event entirely outside the control of the Employer or the Contractor, the Engineer shall certify that the Contractor has been frustrated. The Contractor shall make the site safe and stop works as quickly as possible after receiving this certificate and shall be paid for all works carried out before receiving it and any work carried out afterwards to which commitment was made.

58. Maintenance of ROW

- 58.1 Throughout the period of the Contract, the Contractor shall at all times maintain public vehicular access along the right-of-way to all public and private access and land. The contractor on written request to the Engineer, (including a drawing, program and specification), be given approval to operate.

59. Field Laboratory with Equipment and Tests

- 59.1 Without any extra cost shall provide and maintain adequately equipped field laboratory,
- 59.2 The cost of making any test to be conducted on all types of materials as per quality assurance plan, Tamil Nadu Building Practice/ National Building Code, MoRTH &IRC Specifications, standard procedures and specifications shall be borne by the contractor, and the contractors quoted rates shall include the same.
- 59.3 Third Party Inspection on Factory / Site shall be arranged by the contractor as per the instruction of the Employer. The Employer (or) Third Party Quality Auditor(s) appointed by the Employer shall be entitled to visit Factory / Site, Conduct sampling and Testing on the Products/works in accordance with relevant specifications. The entire expenses towards the third party inspection shall be borne by the contractor.

60. Approval of Proprietary Product / Process / System

Within 7 days of award of the work, the Contractor shall submit the following information for all proprietary products for approval by the Engineer.

The Engineer may instruct and additional tests for the purpose of accepting the product which shall be followed by the Contractor

I. Name of manufacturer and name of product/process/system.

Complete details of manufacturer of the product/process/system shall be furnished. Details of where similar product/process/system has been successfully used be furnished. Authenticated copies of License/ collaboration Agreement shall be furnished.

II General features of the product/product process system.

Detailed write-up with method statements shall be furnished for each product/process system. This shall include complete working drawings and installation drawings, technical specification covering fabrication, material, system of corrosion protection, etc

III Acceptance test and criteria

Manufacturer shall submit a quality assurance system document. Details of acceptance test and criteria of acceptance shall be furnished in this document.

APPENDIX 1

Safety Measures

I Contractor's Liability

The contractor shall be absolutely and solely responsible for any and all kinds of injuries or damages to person and property of any description whatever may be caused by or result from the execution of the works, whether these may have been carried out skillfully and carefully and strictly in conformity with the provisions of the specifications or not.

II Responsibility for Accidents, Damages etc.

The care of the whole of the permanent works shall remain with the contractor who shall be responsible for all accidents or damages from whatever cause arising and chargeable for anything that may be stolen, removed destroyed or damaged to whomsoever belonging and also for making good all defects and damages to the said works or to any property adjoining or any cause whatever whether such damage or defects were occasioned by the negligence of the contractor or not or may be or might have been discovered during the progress of the works or in consequences thereof, or shall appear to be known after the completion whereof or whether payment may wholly or partially have been made or the works approved as supposed to have been properly done and no certificate of approval of any works by any officers of ITEL/TNRDC shall affect or prejudice the right of TNRDC against the contractor or be considered or held as at all conclusive as to the sufficiency of any works or materials.

III Contractor to be responsible for all Trespasses and Damages

In the event of accidents to any person including employees of TNRDC on duty, damages to property, trespass on land, injury to cattle, horses, or other animals or damage injury of any description to any person or thing arising out of the execution of the works, the contractor shall be held responsible for and make good the same and shall indemnify TNRDC from all claims or expenses on account thereof and if TNRDC has to pay any money in respect thereof the sum so paid and the costs incurred by TNRDC shall be charged to the contractor as so much money paid to him on account of his contract and the contractor shall not be at liberty to dispute or question the right of TNRDC to make such payment for him or on his account notwithstanding the same may have been made without his consent of authority and decision or determination in law or otherwise to the contrary notwithstanding. TNRDC shall not be liable to, or for in respect of any damages or compensation or claim there for, under any Act for the time being in force or common law because or by reason or in consequences of any accident or injuries to workmen or others in the employment of the contractor or any subcontractor or of any person acting under him or on his behalf or the staff / persons employed by TNRDC for supervision of the work under his contract and the contractor shall save TNRDC harmless and indemnify in respect thereof and of any all costs and expenses incidental there to or consequent thereon.

IV Safety Measures

1. All the works to be carried out in and around the work site, it must be under the contractors supervision with their supervisor, at their own risk and cost
2. The contractor should possess rubber gloves, gum safety boots, helmet, face mask, torch light, emergency light etc. as safety equipments in good condition
3. Each and every employee of the contractor should have insurance cover under Workmen Compensation Act.
4. The Contractor has to carry out any activity of the construction work only after informing and getting concurrence of TNRDC / Engineer in charge

V Safety Equipments & Loose Tools:

The Contractor will be responsible to make available the safety equipment and loose tools as listed below if the Contractor fails to keep the safety equipment and loose tools and consumable items as listed the above will be procured by TNRDC and the cost will be deducted immediately from the bill payable to the contractor with a penalty of Rs. 2,000/-

VI Safety Measures to be adhered

1. Only experienced, skilled people have to be employed by the contractor
2. All personnel should be covered by insurance under Workmen Compensation Act.
3. All labour act provisions has to be met with
4. Rubber gloves, gum safety boots, helmet, face mask, torch light, emergency light etc are need to be provided by the contractor.
5. Exhibit labels of "Safety First"

VII List of Safety equipments to be provided by the contractor

| SI No | Name of Equipment |
|-------|-------------------------|
| 1 | Face Mask |
| 2 | Shock proof hand gloves |
| 3 | Disposable hand gloves |
| 4 | Gum boot / Safety shoes |
| 5 | First Aid Box |
| 6 | Emergency light |
| 7 | Helmet / hard hat |
| 8 | Safety cones |
| 9 | Traffic barriers |
| 10 | Warning lights |
| 11 | Red flags |
| 12 | Caution boards |

Note: The above is only an illustrative minimum list. The contractor must note that it is their responsibility to ensure the lives and safety of the workers employed by them. Towards this end, all the equipments of appropriate specifications should be procured and made available to the workers in usable conditions throughout the period of contract. Responsibility for any health problem or death will solely rest with contractor.

APPENDIX 2**Labour Statutory Requirements****I General**

The Contractor shall confirm to and comply with the regulations and by-laws of the State or Central Government or TNRDC and of all other local authorities such as Corporation of Chennai, The Tamil Nadu Electricity System, The Chief Electrical Inspector to Government of Tamil Nadu, The Government Customs and Police Departments Fire Service, the provisions contained in the various Labour Acts enacted by the State Legislature and Central Parliament in force and rules made there under including those under Minimum Wages Act, Factories Act, The Indian Electricity Act and rules framed under it, Workmen Compensation Act, The Employees State Insurance Act 1948, Provident Fund Regulations Act, The EPF and Miscellaneous Provisions Act 1952, Employees Provident Fund 1961 and scheme made under the said Act, Health and Sanitary Arrangements for workers etc. and the Contract Labour (Regulation and Abolition) Central Act 1970 and the Contracts (Regulation and Abolition) Central Rules 1971 etc. for Welfare and protection of works, workers or for the safety of the public and other Insurance provisions.

II Further, the Contractor has to give a declaration for the following provisions:-

- i. That in the capacity of Contractor, the Contractor has to comply with the provisions of Contract Labour (Regulation & Abolition) Act, 1970 by obtaining a valid license under the Act and the Rules thereto and similarly under Factories Act wherever applicable.
- ii. The Contractor has to pay the wages in accordance with the Minimum Wages Act to all his / their employees
- iii. That the Contractor has to abide to recover the Employees Provident Fund and the Employees' Insurance contributions (both Employees and employers contribution) from the payment of bills every month
- iv. The Contractor's Code Nos. for E.S.I / Workmen Compensation Policy and E.P.F. are----- & ----- and both the Employees, Employers contributions will be remitted by the contractor in his / their code numbers and copy of the remittance challans will be produced. In case, if the contractor is failing to remit, he / they will inform wage rates of employees to the Principal employer so that they can remit Employees' State Insurance Contribution & Employees Provident Fund contribution (both for employer and employee) and authorize them to make deductions from the payment of bills
- v. That the contractor has to authorize to recover the contributions towards Tamil Nadu Manual Worker (Regulations of Employment and Conditions of work) Act, 1982 fund at the percentage prescribed by the Government from time to time.
- vi. That the contractor has to further declare and undertake that in case of any liability pertaining to his / their employees is to be discharged by the Principal Employer for his / their lapse, the contractor undertake to reimburse the same or the Principal Employer is authorized to deduct the same from the contractor's dues as payable.
- vii. That the contractor will maintain the Registers and records about the Contract Labour employed under Section 29 of Labour (Regulation & Abolition) Act wherever applicable

- viii. That the contractor will take insurance policy under Workmen Compensation Act to meet out any untoward incident until the contract labourers are issued with ESI card

III Compliance with Labour Regulations

During continuance of the contract, the contractor and his sub contractors shall abide at all times by all existing labour enactment's and rules made there under, regulation, notifications and bye laws of the State or Central Governments or local authority and any other labour law (including rules), regulations, bye laws that may be passed or notification that may be issued under any labour law in future either by the State or the Central Government or the local authority. The Contractor shall keep TNRDC indemnified in case any action is taken against TNRDC by the competent authority on account of contravention of any of the provisions of any Act or rules made there under, regulation's or notifications including amendments. If TNRDC is caused to pay or reimburse, such amounts as may be necessary to cause or observe, or for non-observance of the provisions stipulated in the notifications / bye laws / Acts / Rules / Regulations including amendments, if any, on the part of the contractor, the Engineer / TNRDC shall have the right to deduct any money due to the contractor including his amount of performance security. TNRDC /Engineer shall also have right to recover from the Contractor any sum required or estimated to be required for making good the loss or damage suffered by TNRDC.

The employees of the Contractor and the Sub-Contractor in no case shall be treated as the employees of TNRDC at any point of time.

IV Contribution to Fund

Notwithstanding anything contained in any Law for the time being enforced or in any Agreement every person / Contractor who undertakes any Civil work shall be liable to pay a sum at such percent, not exceeding one percent of the total estimated cost of the work as may be fixed by the Government, by notification, as contribution to the fund constituted for the benefit of manual workers in the employment in Civil Works under a scheme, framed under Section 3 of Tamil Nadu Manual Workers (Regulation of Employment and Conditions of Work) Act, 1982. The percentage of total estimated cost of work, as may be fixed by the Government, notification from time to time shall be recovered from the Contractor, deductible at source and remit it to the Tamil Nadu Constructions Workers Welfare Board within such period as may be prescribed.

V Contract Labour Welfare

- i. The rights and benefits conferred on the workmen employed by the contractor under the provisions of various Labour Laws are the responsibility of the contractor. The contractor has to indemnify TNRDC in case of loss or any damages. It is the responsibility of the contractor to take insurance policy under Workmen's compensation Act, 1923 for each labour engaged by the contractor. The contractor will be responsible for any deficiency on safety measures to be adhered as stipulated in Safety measures to be adhered in Appendix 1. A photocopy of the insurance under Workmen's Compensation Policy should be furnished to TNRDC. The policies should be kept alive till the completion of the contract period.
- ii. The Contractor shall produce fitness certificate from any Authorized Medical Attendant (AMA) of Government Hospital for all the Technical Staff and Labour Staff to be employed.

VI Following Laws shall be adhered to by the contractor wherever applicable

- a. Workmen Compensation Act, 1923
- b. Payment of Wages Act, 1936

- c. Industrial Disputes Act, 1947
- d. Minimum Wages Act, 1948
- e. Factories Act, 1948
- f. Employees PF and Miscellaneous Act, 1952
- g. Payment of Bonus Act, 1965
- h. Payment of Gratuity Act, 1972
- i. Equal Remuneration Act, 1979
- j. Maternity Benefit Act, 1951
- k. Contract Labour (Regulation & Abolition) Act 1970
- l. Industrial Employment (Standing Orders) Act 1946
- m. Trade Unions Act 1951
- n. Child Labour (Prohibition & Regulation) Act 1986
- o. Inter-State Migrant Workmen's (Regulation of Employment & Conditions of Service) Act 1979
- p. The Building and other Construction workers (Regulation of Employment and Conditions of Service) Act 1996 and the Cess Act of 1996
- q. Employee State Insurance Act, 1948
- r. The Tamil Nadu Manual Workers (Regulation of Employment and Conditions of Work) Act, 1982
- s. The Bonded Labour System (Abolition) Act, 1976
- t. The Employer's Liability Act, 1938
- u. Skilled / Certified labour notification

VII Elimination of Child Labour

1. Attention of all contractor are invited to the Child Labour (Prohibition and Regulations) Act 1986, which prohibits employment of children below 14 years of age in certain occupations and process and provides for regulations of employment of children in all other occupations and progress. Employment of child labor is prohibited in building and construction industry.
2. Hence, all the contractors are requested to adhere to the provisions in the above Act and see that engagement of child labour in the operational activities of TNRDC are completely prohibited. Any violation of the provision will lead to penal action and removing of the contractor from the list of registered contractors.

APPENDIX 3

Tax Registration Number

We confirm that our firm/company has valid GST/PAN details as under:

- i) GST No. _____
- ii) PAN No. _____
- iii) ESI / Workman Comp. Policy. _____
- iv) EPF _____

**1% Cess to be paid for the Contract Value as per the notification of Tamil Nadu
Manual Workers Act,1982**

(Format to be filled by the successful bidder)

- 1. Name of the Person
In charge of the Construction Work :
- 2. Place of Construction :
- 3. Total Cost of Construction :
- 4. 1% of the Total Cost of
Construction Work :
- 5. DD No., Date, Amount and Bank
On which Demand Draft is drawn :

Section IV

Contract Data

SECTION IV CONTRACT DATA

| Item | Clause Reference |
|--|------------------|
| The listed documents are also part of the contract and enclosed as Appendix | 2.3 |
| Detailed program regarding Work Methodology, Quality control and Assurance Plan to complete the work as per the construction programme | -- |
| Operation and Maintenance Manuals. | 53 |
| <p>The Employer is :</p> <p>Tamil Nadu Road Development Company Ltd. (TNRDC), No.171, II Floor, Tamil Nadu Maritime Board Building, South Kesavaperumal Puram, Pasumpon Muthuramalingam Road, (Near Greenways Road MRTS Station), Raja Annamalai Puram, Chennai 600 028 Phone: 91-44-2495 2800 / 3800, Fax: 91- 44-2493 3800</p> <p>Name of Authorised Representative : Chairman and Managing Director / TNRDC</p> <p>-----</p> <p>Engineer is :</p> <p>Tamil Nadu Road Development Company Ltd., (TNRDC), No.171, II Floor, Tamil Nadu Maritime Board building, South Kesavaperumal Puram, Pasumpon Muthuramalingam Road, (Near Greenways Road MRTS Station), Raja Annamalai Puram, Chennai 600 028 Phone: 91-44-2495 2800 / 3800, Fax: 91- 44-2493 3800</p> <p>Name of Authorised Representative : Chief General Manager</p> | 1.1 |
| <p>The name of the Contract is :</p> <p>“Construction of Road adjacent to IOCL (L&G) Regasification Terminal Road (inside the KPL) Km:0/000 to Km:2/410”</p> | 1.1 |
| The Start Date shall be the date of Contract Agreement | 1.1 |
| Intended Completion Date: is 18 Months from the Date of Contract Agreement | 1.1,16,26 |
| The Contractor Shall submit a Detailed Work Program including Construction Program, Work Methodology, for the works (in such form and detail as the Engineer prescribe. The Program should have adequate details and conform to the contract provisions. | 25 |

| The Site is “ Inside the premises of Kamarajar Port Limited (KPL) ” | 1 | | | | | | | | | | | | |
|---|---|--------------------------|---------------------------|--|--|---|--|--|------------------------|---|-----------------------|---|----|
| The Defects Liability Period is 36 Months after the Completion Date of the construction / improvement works | 50.2 | | | | | | | | | | | | |
| <p>Insurance requirement :</p> <table border="0"> <thead> <tr> <th style="text-align: left;">Item</th> <th style="text-align: left;">Minimum cover for</th> </tr> </thead> <tbody> <tr> <td>Works, Plant and material</td> <td></td> </tr> <tr> <td>Fire policy/ Loss or damage to Equipment value</td> <td>Equivalent to 1.15 times of the contract value</td> </tr> <tr> <td colspan="2"><u>Personal Injury or death Insurance</u></td> </tr> <tr> <td>For other people value</td> <td>Equivalent to 1.15 times of the contract value</td> </tr> <tr> <td>Contractor’s employee</td> <td>In accordance with applicable existing laws</td> </tr> </tbody> </table> | Item | Minimum cover for | Works, Plant and material | | Fire policy/ Loss or damage to Equipment value | Equivalent to 1.15 times of the contract value | <u>Personal Injury or death Insurance</u> | | For other people value | Equivalent to 1.15 times of the contract value | Contractor’s employee | In accordance with applicable existing laws | 13 |
| Item | Minimum cover for | | | | | | | | | | | | |
| Works, Plant and material | | | | | | | | | | | | | |
| Fire policy/ Loss or damage to Equipment value | Equivalent to 1.15 times of the contract value | | | | | | | | | | | | |
| <u>Personal Injury or death Insurance</u> | | | | | | | | | | | | | |
| For other people value | Equivalent to 1.15 times of the contract value | | | | | | | | | | | | |
| Contractor’s employee | In accordance with applicable existing laws | | | | | | | | | | | | |
| The language of the Contract Document is English | 3 | | | | | | | | | | | | |
| The law which applies to the Contract is the Law of Union of India | 3 | | | | | | | | | | | | |
| The currency of the contract is Indian Rupees Only. | 43 | | | | | | | | | | | | |
| <p>Retention money :-</p> <p>In IPC’s @ 5 % of value of each bill will be withheld and the withheld amount will be refunded to the Contractor along with the Final Bill / Taking over certificate.</p> | 39.3 | | | | | | | | | | | | |
| <p>Penalty for not attending Management Meetings/ Site Visits : Rs 1,000/- per incidence</p> <p>The maximum amount of the penalty is 2% of contract Price for Works.</p> | 28.2 | | | | | | | | | | | | |
| <p>The liquidated damages for non-completion of construction Works within the intended completion date shall be 0.5% of balance contract value for each week’s delay or part there of beyond the completion date. The maximum amount of liquidated damages for the whole of the works is 5% final Contract Price for Works.</p> <p>In case of default performance on the part of the contractor to engage required personnel for the work as stipulated in Clause 9.3, a penalty of Rs.20,000/- per month for the Diploma holder and Rs.30,000/- per month for the Degree holder shall be levied based on the norms for the value of this contract.</p> | 45.1 | | | | | | | | | | | | |
| <p>Performance Security shall be of 2% of Contract Price for Construction Works as stated in the Acceptance letter / work order, valid for a period of 58 Months. If the performance security is in the form of Bank Guarantee, the same shall be valid for a period of 58 Months from the date of Bank Guarantee or 03 months beyond the Defect Liability period whichever is later. The standard form of Performance Security acceptable to the Employer shall be an unconditional and irrevocable Bank Guarantee of the type as presented in section – II of Bidding Documents.</p> | 48 | | | | | | | | | | | | |
| <p>Hard copy and a soft copy of “As- Built” Drawings (in scale as per codal specifications) and Operation and Maintenance manuals are required before issuing the “Certificate of Completion of Works”.</p> <p>The amount to be withheld for failing to supply the “As- Built” Drawings and Operation and Maintenance Manuals within the date required is Rs. 2 Lakhs.</p> | 53 | | | | | | | | | | | | |

Section V

Bill of Quantities

Bill of Quantities (BoQ) for works

A. Preamble

1. The Bill of Quantities shall be read in conjunction with the Instruction to Bidders, General and Special Conditions of Contract, Technical Specifications and conforming to the Indian standard specification.
2. The Bidder should closely peruse all the specification clauses for items of works for which he is tendering his rates.
3. The quantities given in the Bill of Quantities are approximate and provisional, which are given to provide a common basis for making payment for works. Actual quantities of work are likely to increase or decrease as per the requirement at site. Hence there is no claim for any additional or less quantities than the specified in the BOQ.
4. The rates in the Bill of Quantities shall except in so far as it is otherwise provided under the Contract, include all plant, labour, supervision, materials, erection, transportation, maintenance, insurance, Toll, administrative overheads, profit, taxes and duties, together with all general risks, liabilities and obligations set out or implied in the Contract.
5. General directions and description of work and materials are not necessarily repeated nor summarized in the Bill of Quantities. The whole cost of complying with the provisions of the Contract shall be included in the items provided in the Bill of Quantities.

Construction of Road adjacent to IOCL (L&G) Regasification Terminal Road (inside the KPL) Km:0/000 to Km:2/410

Bill of Quantities

| S.No | MoRTH Specification No. | Description of Item | Unit | Quantity | Rate(Rs) inclusive of GST | | Amount(Rs) inclusive of GST |
|------|-------------------------|---|-------|----------|---------------------------|----------|-----------------------------|
| | | | | | In Figures | In Words | |
| 1 | 201 | Clearing and grubbing road land including uprooting rank vegetation, grass, bushes, shrubs, saplings and trees girth up to 300 mm, removal of stumps of trees cut earlier and disposal of unserviceable materials and stacking of serviceable material to be used or auctioned, up to a lead of 1000 metres including removal and disposal of top organic soil not exceeding 150 mm in thickness. | Hect. | 4.63 | | | |
| 2 | 202 | Dismantling of flexible pavements and disposal of dismantled materials up to a lead of 1000 metres, stacking serviceable and unserviceable materials separately as directed by the Engineer-in-charge | Cum. | 5905.00 | | | |
| 3 | 305 | Embankment Construction with approved Material (Construction of embankment with approved material deposited at site from roadway cutting and excavation from foundation of structures, spreading, grading to required slope and compacting to meet requirement of table 300-2) | Cum. | 13014.00 | | | |

Construction of Road adjacent to IOCL (L&G) Regasification Terminal Road (inside the KPL) Km:0/000 to Km:2/410

Bill of Quantities

| S.No | MoRTH Specification No. | Description of Item | Unit | Quantity | Rate(Rs) inclusive of GST | | Amount(Rs) inclusive of GST |
|------|-------------------------|---|------|----------|---------------------------|----------|-----------------------------|
| | | | | | In Figures | In Words | |
| 4 | 305 | Embankment Construction with Material Obtained from Borrow Pits (Construction of embankment with approved material obtained from borrow pits with all lifts and leads, transporting to site, spreading, grading to required slope and compacting to meet requirement of table 300-2) | Cum. | 18280.00 | | | |
| 5 | 401 | Construction of Granular Sub-Base by providing close graded Material, mixing in a mechanical mix plant at OMC, carriage of mixed Material to work site, spreading in uniform layers with motor grader on prepared surface and compacting with vibratory power roller to achieve the desired density, complete as per clause 401 | Cum. | 7230.00 | | | |

Construction of Road adjacent to IOCL (L&G) Regasification Terminal Road (inside the KPL) Km:0/000 to Km:2/410

Bill of Quantities

| S.No | MoRTH Specification No. | Description of Item | Unit | Quantity | Rate(Rs) inclusive of GST | | Amount(Rs) inclusive of GST |
|------|-------------------------|--|------|----------|---------------------------|----------|-----------------------------|
| | | | | | In Figures | In Words | |
| 6 | 601 | Construction of Dry lean cement concrete (DLC)Sub-base over a prepared sub-grade with coarse and fine aggregate conforming to IS: 383, the size of coarse aggregate not exceeding 25 mm, aggregate cement ratio not to exceed 15:1, aggregate gradation after blending to be as per table 600-1, cement content not to be less than 150 kg/ cum, optimum moisture content to be determined during trial length construction, concrete strength not to be less than 10 Mpa at 7 days, mixed in a batching plant, transported to site, laid with a paver with electronic sensor, compacting with 8-10 tonnes vibratory roller, finishing and curing. | Cum. | 3615.00 | | | |

Construction of Road adjacent to IOCL (L&G) Regasification Terminal Road (inside the KPL) Km:0/000 to Km:2/410

Bill of Quantities

| S.No | MoRTH Specification No. | Description of Item | Unit | Quantity | Rate(Rs) inclusive of GST | | Amount(Rs) inclusive of GST |
|------|-------------------------|--|------|----------|---------------------------|----------|-----------------------------|
| | | | | | In Figures | In Words | |
| 7 | 602 | PQC- Construction of un-reinforced, dowel jointed, plain cement concrete pavement over a prepared sub base with M40 grade cement concrete as per design mix , coarse and fine aggregate conforming to IS 383, maximum size of coarse aggregate not exceeding 25 mm, mixed in a batching and mixing plant as per approved mix design, transported to site, laid with a fixed form or slip form paver, spread, compacted and finished in a continuous operation including provision of contraction, expansion, construction and longitudinal joints, joint filler, separation membrane, sealant primer, joint sealant, debonding strip, dowel bar, tie rod, admixtures as approved, curing compound, finishing to lines and grades as per drawing CEMENT CONCRETE PAVEMENT | Cum. | 7230.00 | | | |

Construction of Road adjacent to IOCL (L&G) Regasification Terminal Road (inside the KPL) Km:0/000 to Km:2/410

Bill of Quantities

| S.No | MoRTH Specification No. | Description of Item | Unit | Quantity | Rate(Rs) inclusive of GST | | Amount(Rs) inclusive of GST |
|------|-------------------------|--|------|----------|---------------------------|----------|-----------------------------|
| | | | | | In Figures | In Words | |
| 8 | 409 | Cast in Situ Cement Concrete M20 kerb (Construction of cement concrete kerb with top and bottom width 115 and 165 mm respectively, 250 mm high in M 20 grade PCC on M-10 grade foundation 150 mm thick, foundation having 50 mm projection beyond kerb stone, kerb stone laid with kerb laying machine, foundation concrete laid manually, all complete as per clause 409) | Rm. | 4820.00 | | | |
| 9 | 2504 | Auxiliary Berms in Providing and laying Gravel Filter Media for Turfing with 150mm gravel packing over Gravel 300mm thickness etc.,complete as per drawing and Technical specification and as directed by the Engineer-in-charge | Cum. | 7791.00 | | | |
| 10 | 307 | Auxiliary Berms in Providing and laying Turfing with 150mm gravel packing.,complete as per drawing and Technical Specification and as directed by the Engineer-in-charge | Sqm | 16089.00 | | | |

Construction of Road adjacent to IOCL (L&G) Regasification Terminal Road (inside the KPL) Km:0/000 to Km:2/410

Bill of Quantities

| S.No | MoRTH Specification No. | Description of Item | Unit | Quantity | Rate(Rs) inclusive of GST | | Amount(Rs) inclusive of GST |
|------|-------------------------|---|-------|----------|---------------------------|----------|-----------------------------|
| | | | | | In Figures | In Words | |
| 11 | 1700 | Construction of Chute Drain with cement concrete (75mm Thick) M15 grade complete as per drawing and Technical specification and as directed by the Engineer-in-charge | Cum. | 35.00 | | | |
| 12 | 1700 | Construction of Saucer drain on both sides of the road edge with cement concrete M15 grade complete as per drawing and Technical Specification and as directed by the Engineer-in-charge | Cum. | 651.00 | | | |
| | | BOX CULVERT | | | | | |
| 13 | 304 | Excavation for Structures (Earth work in excavation of foundation of structures as per drawing and technical specification, including setting out, construction of shoring and bracing, removal of stumps and other deleterious matter, dressing of sides and bottom and backfilling with approved material.) | Cu.m. | 97.00 | | | |

Construction of Road adjacent to IOCL (L&G) Regasification Terminal Road (inside the KPL) Km:0/000 to Km:2/410

Bill of Quantities

| S.No | MoRTH Specification No. | Description of Item | Unit | Quantity | Rate(Rs) inclusive of GST | | Amount(Rs) inclusive of GST |
|------|-------------------------|--|-------|----------|---------------------------|----------|-----------------------------|
| | | | | | In Figures | In Words | |
| 14 | 2504 | Providing and laying of Filter media with granular materials/stone crushed aggregates satisfying the requirements laid down in clause 2504.2.2. of MoRTH specifications to a thickness of not less than 600 mm with smaller size towards the soil and bigger size towards the wall and provided over the entire surface behind abutment, wing wall and return wall to the full height compacted to a firm condition complete as per drawing and technical specification. | Cu.m. | 140.00 | | | |
| 15 | 1500, 1700 & 2100 | Cement Concrete M15 Grade mix for Levelling Course below Bottom Slab of Box Culverts | Cu.m. | 33.00 | | | |
| 16 | 1500, 1700 & 2100 | Reinforced cement concrete in M30 grade as per design mix for base slab etc complete as per drawing and technical specifications | Cu.m. | 63.00 | | | |
| 17 | 1500, 1700 & 2200 | Reinforced cement concrete in M30 grade as per design mix for side walls etc complete as per drawing and technical specifications | Cu.m. | 64.00 | | | |

Construction of Road adjacent to IOCL (L&G) Regasification Terminal Road (inside the KPL) Km:0/000 to Km:2/410

Bill of Quantities

| S.No | MoRTH Specification No. | Description of Item | Unit | Quantity | Rate(Rs) inclusive of GST | | Amount(Rs) inclusive of GST |
|------|-------------------------|--|-------|----------|---------------------------|----------|-----------------------------|
| | | | | | In Figures | In Words | |
| 18 | 1500 & 1600 1700 | Reinforced cement concrete in M30 grade as per design mix for Cover slab etc complete as per drawing and technical specifications | Cu.m. | 33.00 | | | |
| 19 | Section 1600 & 2200 | Supplying, fabricating and placing HYSD bar reinforcement Fe 500 D for RCC items etc complete as per drawing and technical specifications | MT | 15.00 | | | |
| 20 | 809 | Reinforced Cement Concrete Crash Barrier (Provision of an Reinforced cement concrete crash barrier at the edges of the road, approaches to bridge structures and medians, constructed with M-40 grade concrete as per design mix with HYSD reinforcement Fe-500D conforming to IRC:21 as per design to MOST circular No. RW/NH - 33022/1/94-DO III dated 24 June 1994 as per dimensions in the approved drawing and at locations directed by the Engineer, all as specified) | RM | 15.00 | | | |
| 21 | 2705 | Providing and fixing of Drainage Spouts complete as per drawing and Technical specification | No. | 6.00 | | | |

Construction of Road adjacent to IOCL (L&G) Regasification Terminal Road (inside the KPL) Km:0/000 to Km:2/410

Bill of Quantities

| S.No | MoRTH Specification No. | Description of Item | Unit | Quantity | Rate(Rs) inclusive of GST | | Amount(Rs) inclusive of GST |
|------|-------------------------|--|-------|----------|---------------------------|----------|-----------------------------|
| | | | | | In Figures | In Words | |
| 22 | 2706 | Providing and fixing Seepage Pipes (weep holes) of 100mm diameter PVC pipes as per Technical specifications | No. | 157.00 | | | |
| 23 | 2200 | Back filling behind abutment / RCC box side wall, with granular material etc complete as per drawing and Technical specification | Cu.m. | 235.00 | | | |
| 24 | 2507 | Flexible Apron :Construction of flexible apron 1 m thick comprising of loose stone boulders weighing not less than 40 kg beyond curtain wall. | Cu.m. | 90.00 | | | |
| 25 | | Providing and fixing of 150mm dia PVC pipe for Cable Duct provided in Crash Barrier as directed by the Engineer-in-charge | RM | 15.00 | | | |
| 26 | 800 | Painting on concrete surface (Providing and applying 2 coats of water based cement paint to unplastered concrete surface after cleaning the surface of dirt, dust, oil, grease, efflorescence and applying paint @ of 1 litre for 2 Sq.m.) | Sq.m. | 120.00 | | | |

Construction of Road adjacent to IOCL (L&G) Regasification Terminal Road (inside the KPL) Km:0/000 to Km:2/410

Bill of Quantities

| S.No | MoRTH Specification No. | Description of Item | Unit | Quantity | Rate(Rs) inclusive of GST | | Amount(Rs) inclusive of GST |
|------|-------------------------|---|-------|----------|---------------------------|----------|-----------------------------|
| | | | | | In Figures | In Words | |
| | | PIPE CULVERT | | | | | |
| 27 | 304 | Earth work Excavation in all classes of soils except hard rock requiring blasting and depositing on bank with all leads and lifts as per SS20B including cost of all labour, materials, tools, equipments and all incidental charges and sheeting, shoring, bracing and their subsequent removal, removal of all logs, stumps and other deleterious matter and obstructions, trimming of bottom of excavation backfilling, and clearing the site and disposal of all surplus materials etc. complete as per standard specification for FOUNDATION of PIPE CULVERTS. | Cu.m. | 60.00 | | | |
| 28 | 1500 & 1700 | Cement concrete M10 Grade using 40mm ISS size hard broken granite metal including cost and conveyance of all materials to site, including cost and labour charges for form work and centering, labour charges for compacting, curing and all incidental charges etc., complete as per standard specification for LEVELLING COURSE BELOW FACE WALLS OF PIPE CULVERT | Cu.m. | 8.00 | | | |

Construction of Road adjacent to IOCL (L&G) Regasification Terminal Road (inside the KPL) Km:0/000 to Km:2/410

Bill of Quantities

| S.No | MoRTH Specification No. | Description of Item | Unit | Quantity | Rate(Rs) inclusive of GST | | Amount(Rs) inclusive of GST |
|------|-------------------------|---|-------|----------|---------------------------|----------|-----------------------------|
| | | | | | In Figures | In Words | |
| 29 | 1500, 1700 & 2100 | Plain cement concrete of grade M15 using 20mm ISS hard broken granite metal including cost and conveyance of all materials to site and cost of cement including cost of form work, labour charges for mixing, transporting, laying and curing concrete, working at depth, hire charges for tools and plants including all other incidental charges etc., complete for FACE WALLS OF PIPE CULVERTS | Cu.m. | 78.00 | | | |
| 30 | 2900 | Filling behind Face walls and around the pipe with clean gritty free draining gravel including cost of gravel having pi value more than 40, conveyance of gravel to worksite. Laying, handling charges and filling in layers tamping under optimum moisture content to get the maximum density, including watering, with all leads and lifts for water and all other incidental charges etc., complete. | Cu.m. | 87.00 | | | |
| 31 | 2504 | Providing and laying boulders apron on river bed for protection against scour with stone boulders weighing not less than 40 kg each complete as per drawing and Technical specification. | Cu.m. | 44.00 | | | |

Construction of Road adjacent to IOCL (L&G) Regasification Terminal Road (inside the KPL) Km:0/000 to Km:2/410

Bill of Quantities

| S.No | MoRTH Specification No. | Description of Item | Unit | Quantity | Rate(Rs) inclusive of GST | | Amount(Rs) inclusive of GST |
|------|-------------------------|---|-------|----------|---------------------------|----------|-----------------------------|
| | | | | | In Figures | In Words | |
| 32 | 2504 | Providing and laying Stone Pitching on slopes laid over prepared filter media including boulder apron laid dry in front of toe of embankment complete as per drawing and Technical specifications | Cu.m. | 30.00 | | | |
| 33 | 1406 | Pointing with CM 1:3 for Stone Pitching including cost and conveyance of all materials to work site including all labour and other incidental charges etc. complete | Sqm | 92.00 | | | |
| 34 | 2900 | Laying and fixing of RCC pipe NP4 class for culverts on first class bedding of granular material in single row including fixing collar with cement mortar 1:2 but excluding excavation, protection works, backfilling, concrete and masonry works in head walls and parapets.- 1200mm Dia. | RM | 20.00 | | | |

Construction of Road adjacent to IOCL (L&G) Regasification Terminal Road (inside the KPL) Km:0/000 to Km:2/410

Bill of Quantities

| S.No | MoRTH Specification No. | Description of Item | Unit | Quantity | Rate(Rs) inclusive of GST | | Amount(Rs) inclusive of GST |
|------|-------------------------|--|------|----------|---------------------------|----------|-----------------------------|
| | | | | | In Figures | In Words | |
| 35 | 803 | Road Marking with Hot Applied Thermoplastic Compound with Reflectorising Glass Beads on Concrete/ Bituminous Surface (Providing and laying of hot applied thermoplastic compound 2.5 mm thick including reflectorising glass beads @250 gms per sqm area, thickness of 2.5 mm is exclusive of surface applied glass beads as per IRC:35.The finished surface to be level, uniform and free from streaksand holes.) | Sqm. | 803.00 | | | |
| 36 | Special | Relocation of Street Light of 9m length GI steel tubular double bracket pole, LED light fittings, UG cables & civil works with cement concrete M15 grade of size 0.5x0.5x1 m including all labour charges and other incidental charges etc | Nos. | 43 | | | |
| 37 | Special | Providing and fixing of Street Light of 9m length GI steel tubular double bracket pole, LED light fittings, UG cables & civil works with cement concrete M15 grade of size 0.5x0.5x1 m including all labour charges and other incidental charges etc | Nos. | 37 | | | |

Construction of Road adjacent to IOCL (L&G) Regasification Terminal Road (inside the KPL) Km:0/000 to Km:2/410

Bill of Quantities

| S.No | MoRTH Specification No. | Description of Item | Unit | Quantity | Rate(Rs) inclusive of GST | | Amount(Rs) inclusive of GST |
|------|-------------------------|--|------|----------|---------------------------|----------|-----------------------------|
| | | | | | In Figures | In Words | |
| 38 | 806 | Supplying and fixing of Roadway Indicator 1000mm high made by 100mm square MS pipe containing rectangular reflector of 120mm x 80mm and alternate white and black bands of 150mm including coverage of reflector by 150mm high wire mesh | Nos. | 20 | | | |
| 39 | 804 | Providing and fixing of road stud 100x 100 mm, die-Cast in aluminium, resistant to corrosive effect of salt and grit, fitted with lense reflectors, installed in concrete or asphaltic surface by drilling hole 30 mm upto a depth of 60 mm and bedded in a suitable bituminous grout or epoxy mortar, as per clause 804 | Nos. | 1030 | | | |

Construction of Road adjacent to IOCL (L&G) Regasification Terminal Road (inside the KPL) Km:0/000 to Km:2/410

Bill of Quantities

| S.No | MoRTH Specification No. | Description of Item | Unit | Quantity | Rate(Rs) inclusive of GST | | Amount(Rs) inclusive of GST |
|--|-------------------------|---|------|----------|---------------------------|----------|-----------------------------|
| | | | | | In Figures | In Words | |
| 40 | 805 | Kilo Metre Stone/Hectometre Stone/Boundary Stone (Reinforced cement concrete M15 grade KM/HM/Boundary stone of standard design as per IRC:8-1980, fixing in position with cement concrete M15 including Painting & Drilling etc | | | | | |
| | | i) Stones for marking Road no./Name | Nos. | 2 | | | |
| | | ii) Kilometer Stones | Nos. | 8 | | | |
| | | iii) Hectometer Stones | Nos. | 22 | | | |
| | | iv) Boundary Stones | Nos. | 54 | | | |
| Total Amount(Rs) inclusive of GST | | | | | | | |
| (Rupees _____ only) inclusive of GST and all other applicable taxes | | | | | | | |

Section VI

Drawings

PLAN SHOWING FOR LNG ROAD

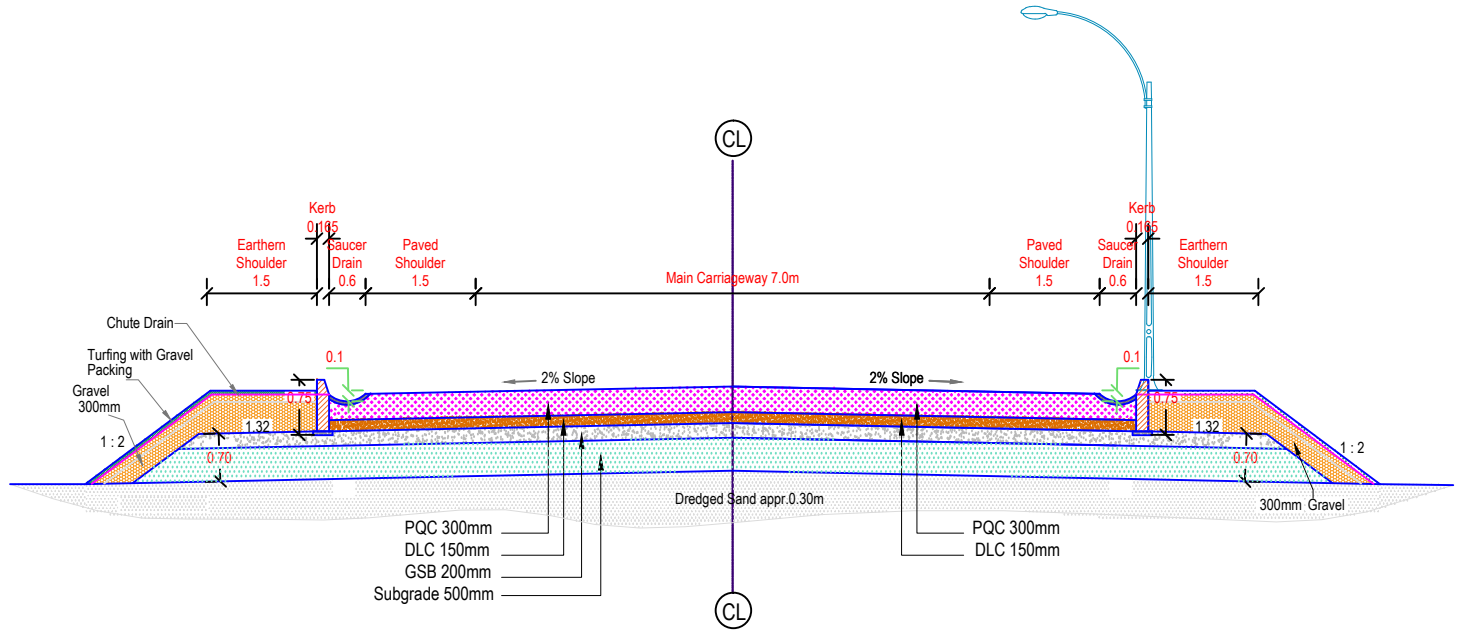
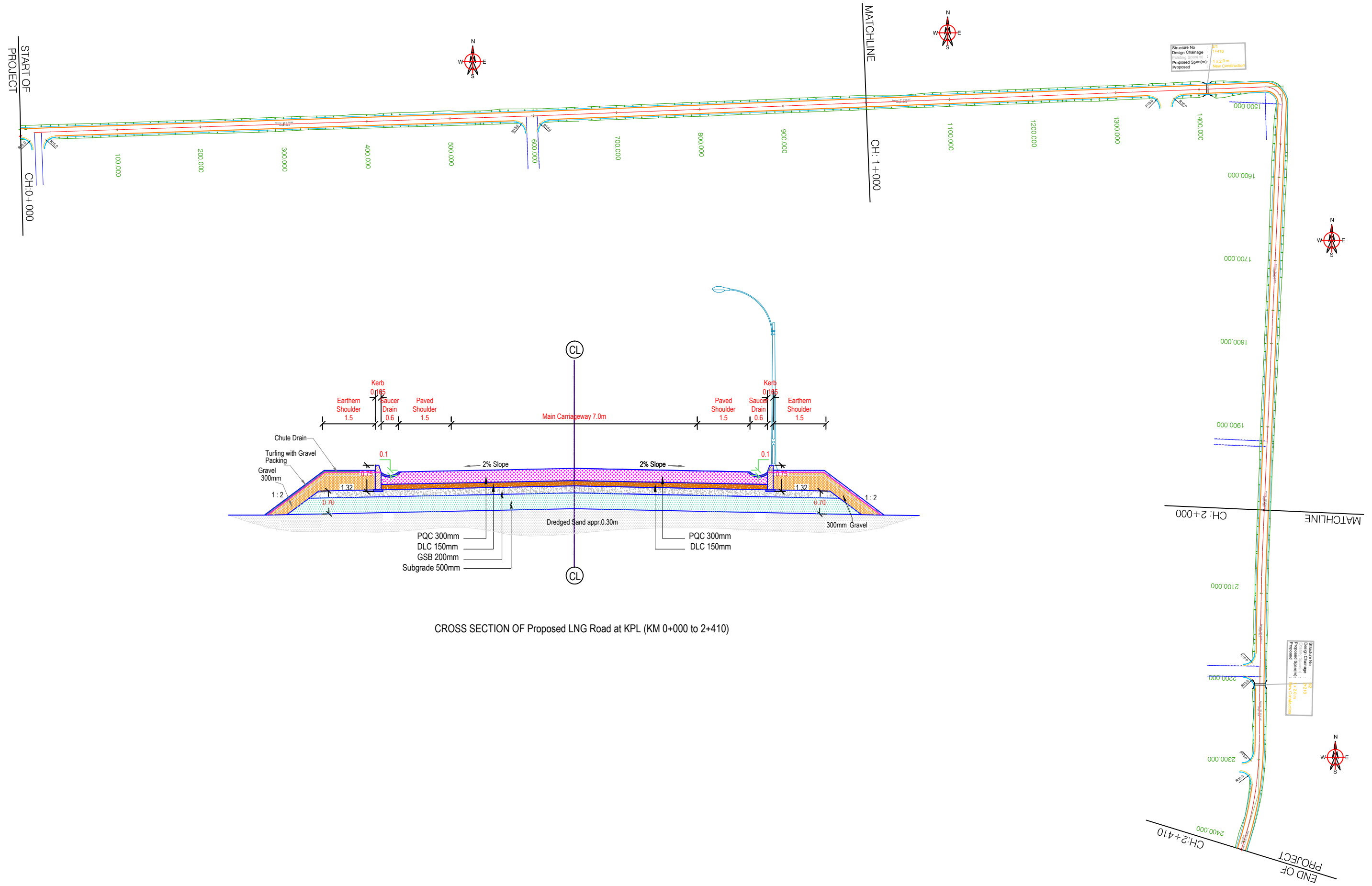

CROSS SECTION OF Proposed LNG Road at KPL (KM 0+000 to 2+410)

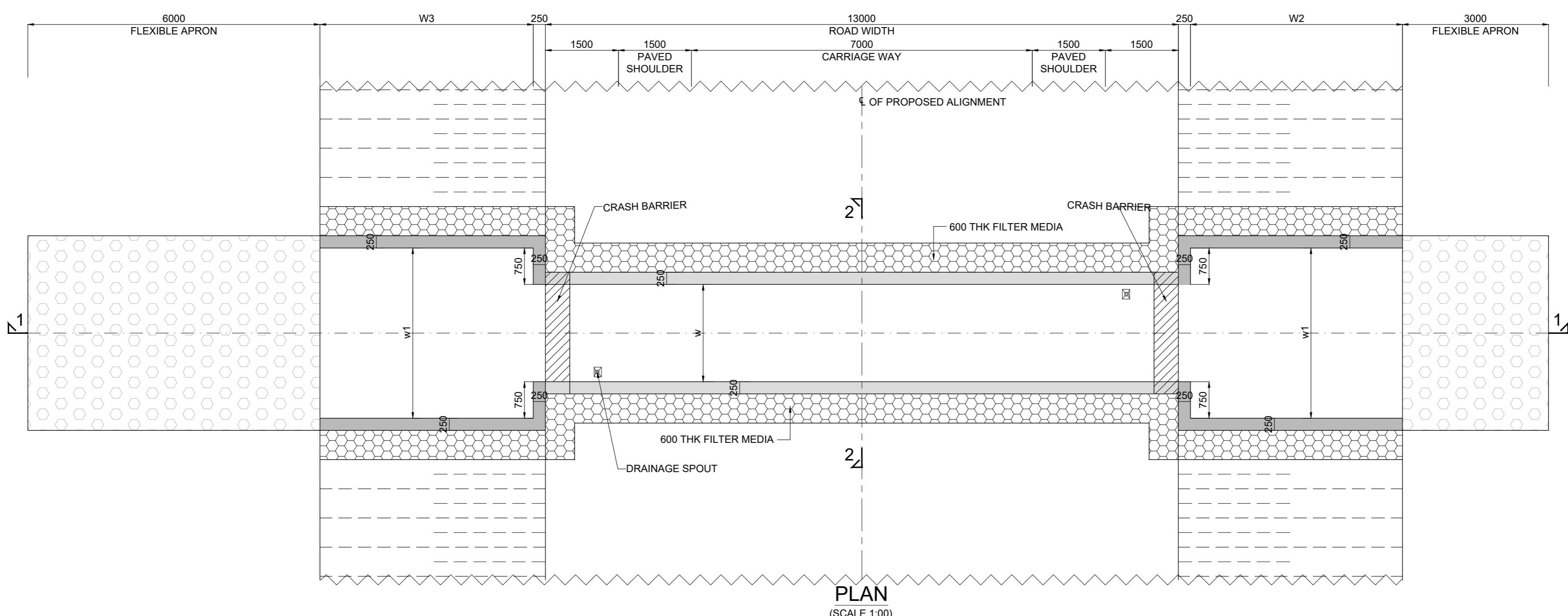
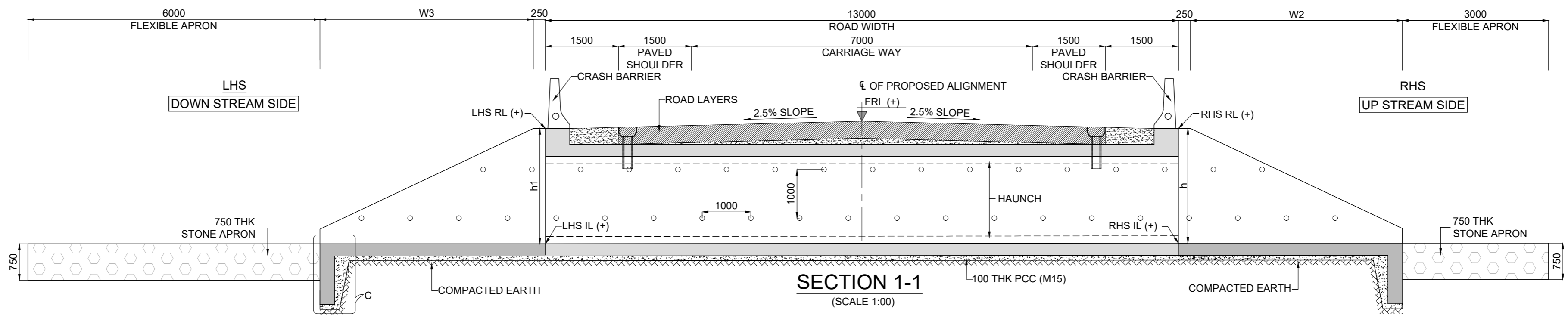

| | | | | | | |
|-----|------------|---------------------|------|-----|------|------|
| REV | DATE | DESCRIPTION | DSND | DWN | CHKD | APPD |
| R0 | 04-06-2020 | ISSUED FOR APPROVAL | | | | |

CLIENT :
TNRDC TAMILNADU ROAD DEVELOPMENT COMPANY LTD
Tamil Nadu Road Development Company Ltd

PROJECT:
 CONSTRUCTION OF ROAD ADJACENT TO IOCL (L&G) REGASIFICATION TERMINAL ROAD (INSIDE THE KPL)

DESIGN CONSULTANT :
VAX CONSULTANTS PVT. LTD
Foundation & Structural Engineers

- GENERAL NOTES :**
- DO NOT SCALE THE DRAWING.
 - REFER DIMENSIONS ONLY.
 - ALL DIMENSIONS ARE IN M UNLESS OTHERWISE SPECIFIED.
 - CHAINAGES ARE IN "M"

| | |
|------------------|-----|
| JOB No. : | |
| DESIGNED | LMR |
| DRAWN | PVK |
| CHECKED | LMR |
| APPROVED | VVV |
| DATE | |

TITLE :
 GENERAL ARRANGEMENT DRAWING FOR NEW & RECONSTRUCTION OF RCC BOX CULVERT

DRAWING NO :
 TNRDC-KPL/DPR/2020/STR/BC/RC/1x2.0m/WD-01

SIZE : **SCALE :** **SHEET NO :** 01 OF 04

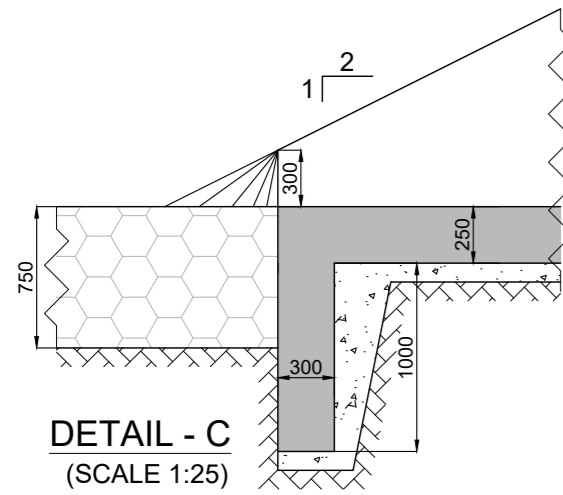
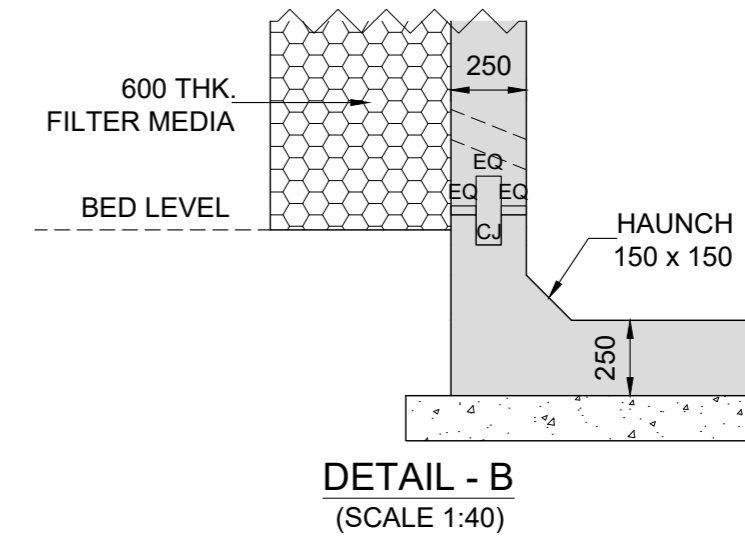
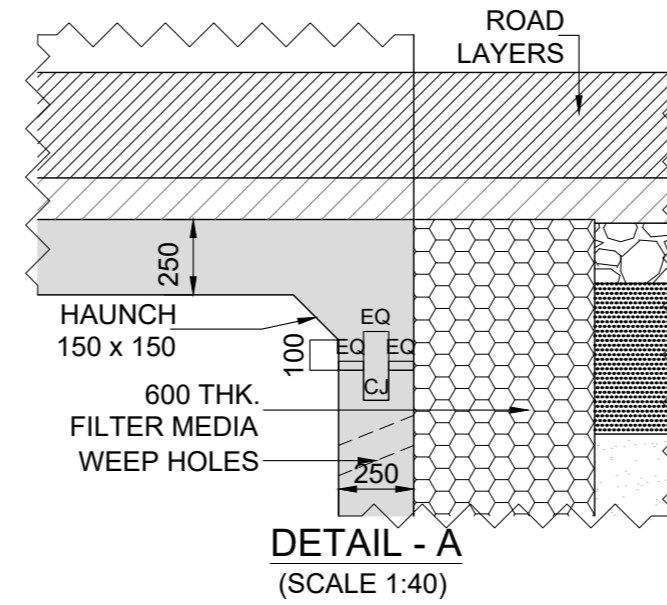
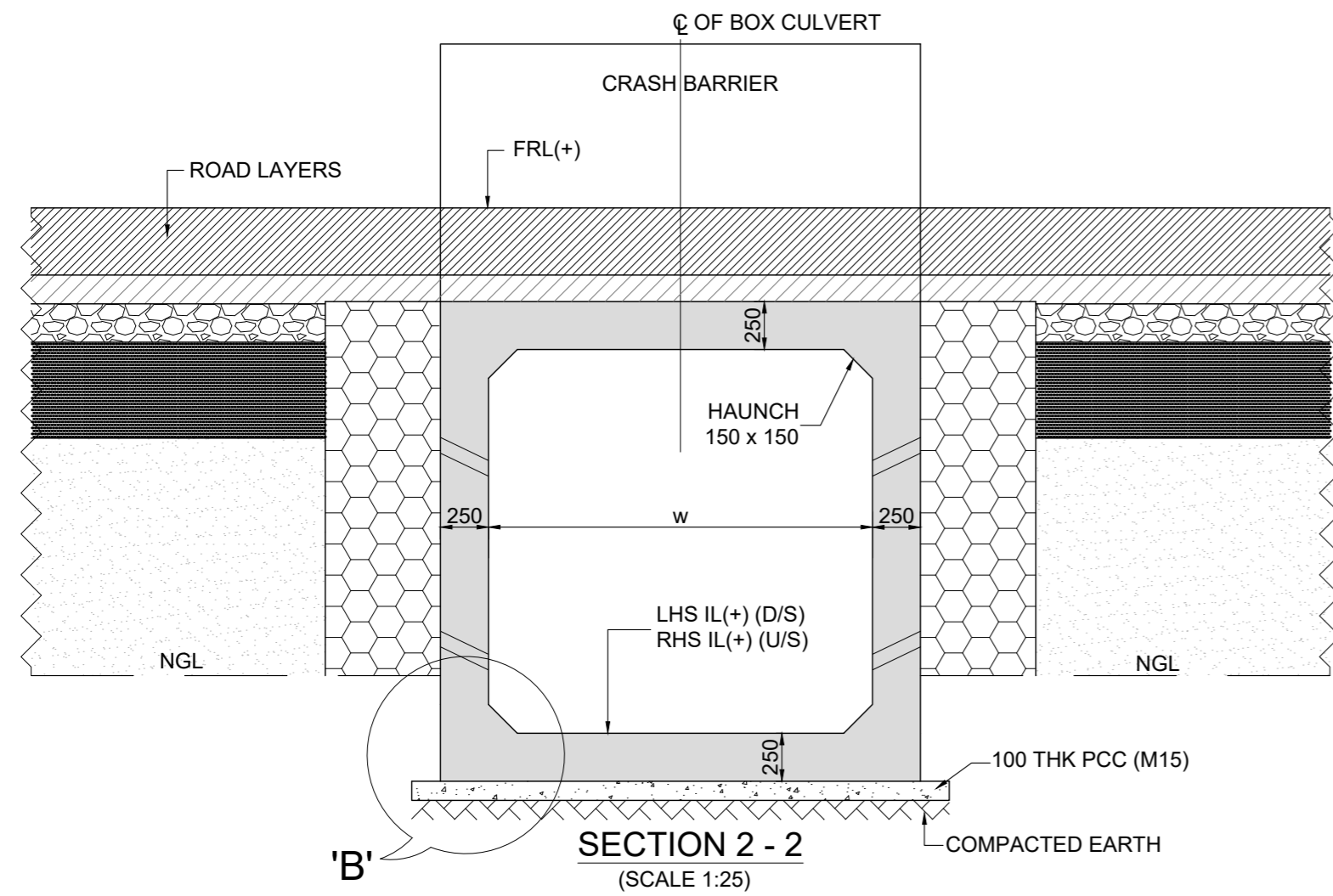

REFERENCE DRAWINGS:-

- | | | |
|--------------------------------------|---|---|
| 1. GENERAL ARRANGEMENT DRAWING | - | TNRDC - KPL / DPR / 2020 / STR / BC / 1 x 2.0m / WD - 01 (01 OF 04) |
| 2. REINFORCEMENT DRAWING FOR RCC BOX | - | TNRDC - KPL / DPR / 2020 / STR / BC / 1 x 2.0m / WD - 01 (03 OF 04) |
| 3. REINFORCEMENT DRAWING FOR RCC BOX | - | TNRDC - KPL / DPR / 2020 / STR / BC / 1 x 2.0m / WD - 01 (04 OF 04) |
| 4. | | |

NOTE:

1. FOR GENERAL NOTES REFER DRAWING NO. TNRDC - KPL / DPR / 2020 / STR / BC / 1 x 2.0m / WD - 01 (03 OF 04)

| Sl. No. | Design Chainage (km) | FRL RL (+) | | | IL(+) | | Camber in % | | w | w1 | w2 | w3 | h | h1 |
|---------|----------------------|------------|--------|-------|-------|-------|-------------|--------|-------|-------|-------|-------|-------|-------|
| | | LHS | CENTRE | RHS | LHS | RHS | LHS | RHS | | | | | | |
| 1 | 1+430 | 5.177 | 5.327 | 5.177 | 1.993 | 2.006 | -2.50% | -2.50% | 2.000 | 3.500 | 5.742 | 5.768 | 3.171 | 3.184 |
| 2 | 2+230 | 4.215 | 4.365 | 4.215 | 2.330 | 2.343 | -2.50% | -2.50% | 2.000 | 3.500 | 3.144 | 3.170 | 1.872 | 1.885 |

| | | | | | |
|-----|------------|---------------------|------|-----|------|
| RO | 04-06-2020 | ISSUED FOR APPROVAL | | | |
| REV | DATE | DESCRIPTION | DSND | DWN | CHKD |
| | | | | | APPD |

CLIENT : **TNRDC** TAMILNADU ROAD DEVELOPMENT COMPANY LTD
 DESIGN CONSULTANT : **VAX CONSULTANTS** Pvt. Ltd
 Foundation & Structural Engineers
 PROJECT : CONSTRUCTION OF ROAD ADJACENT TO IOCL (L&G) REGASIFICATION TERMINAL ROAD (INSIDE THE KPL)

DESIGN CONSULTANT : **VAX CONSULTANTS** Pvt. Ltd
 Foundation & Structural Engineers

GENERAL NOTES :
 1. DO NOT SCALE THE DRAWING.
 2. REFER DIMENSIONS ONLY.
 3. ALL DIMENSIONS ARE IN M UNLESS OTHERWISE SPECIFIED.
 4. CHAINAGES ARE IN "M"

JOB No. :
 DESIGNED LMR
 DRAWN PVK
 CHECKED LMR
 APPROVED VVV
 DATE

TITLE : GENERAL ARRANGEMENT DRAWING FOR NEW & RECONSTRUCTION OF RCC BOX CULVERT
 DRAWING NO : TNRDC-KPL/DPR/2020/STR/BC/1x2.0m/WD-01
 SIZE : SCALE : SHEET NO: 02 OF 04

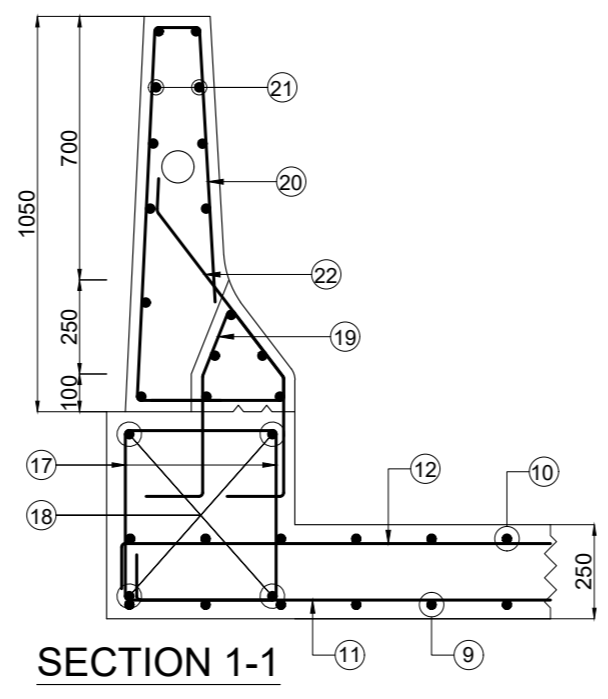
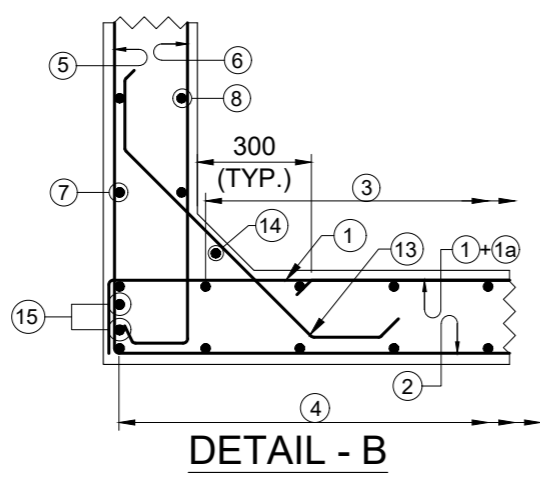
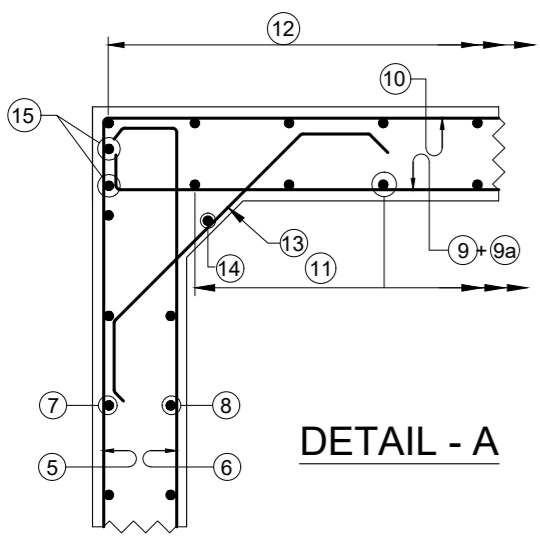
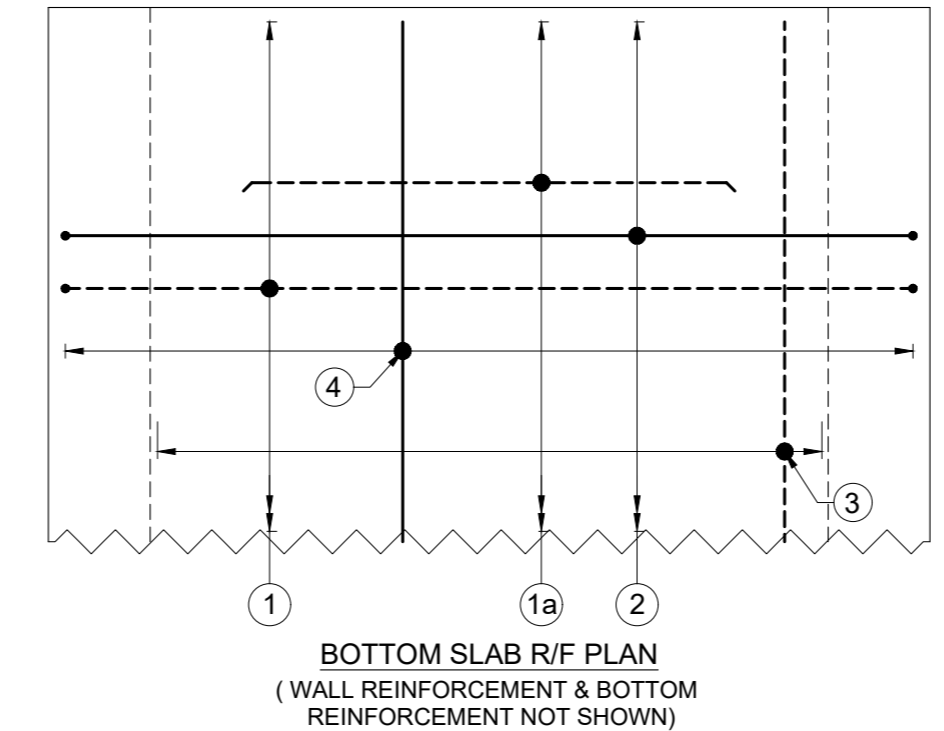
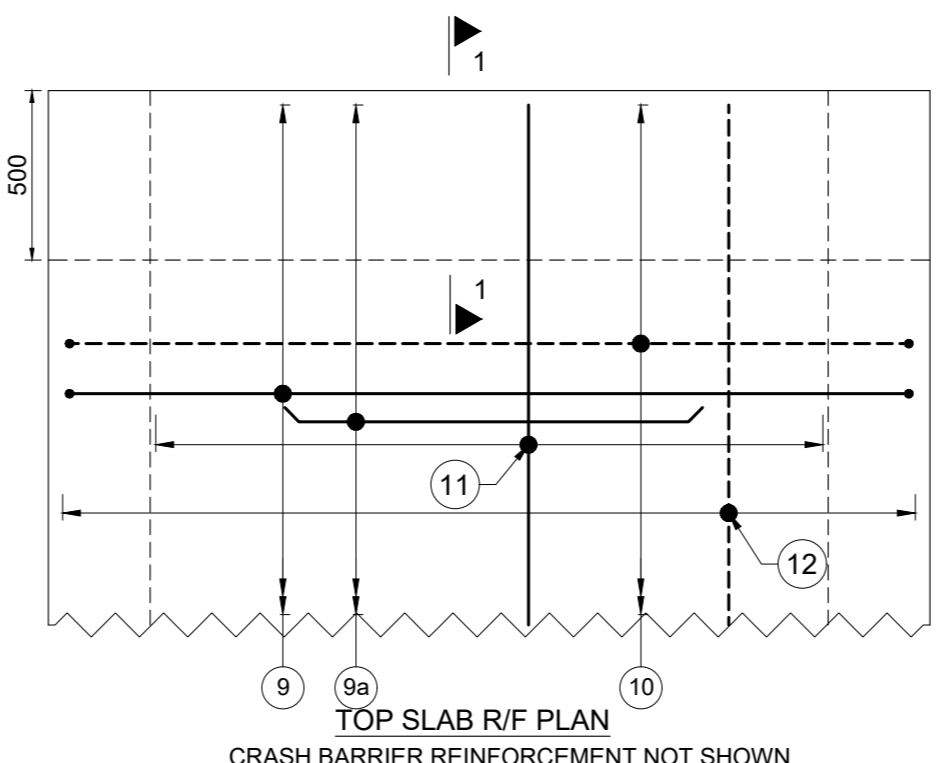
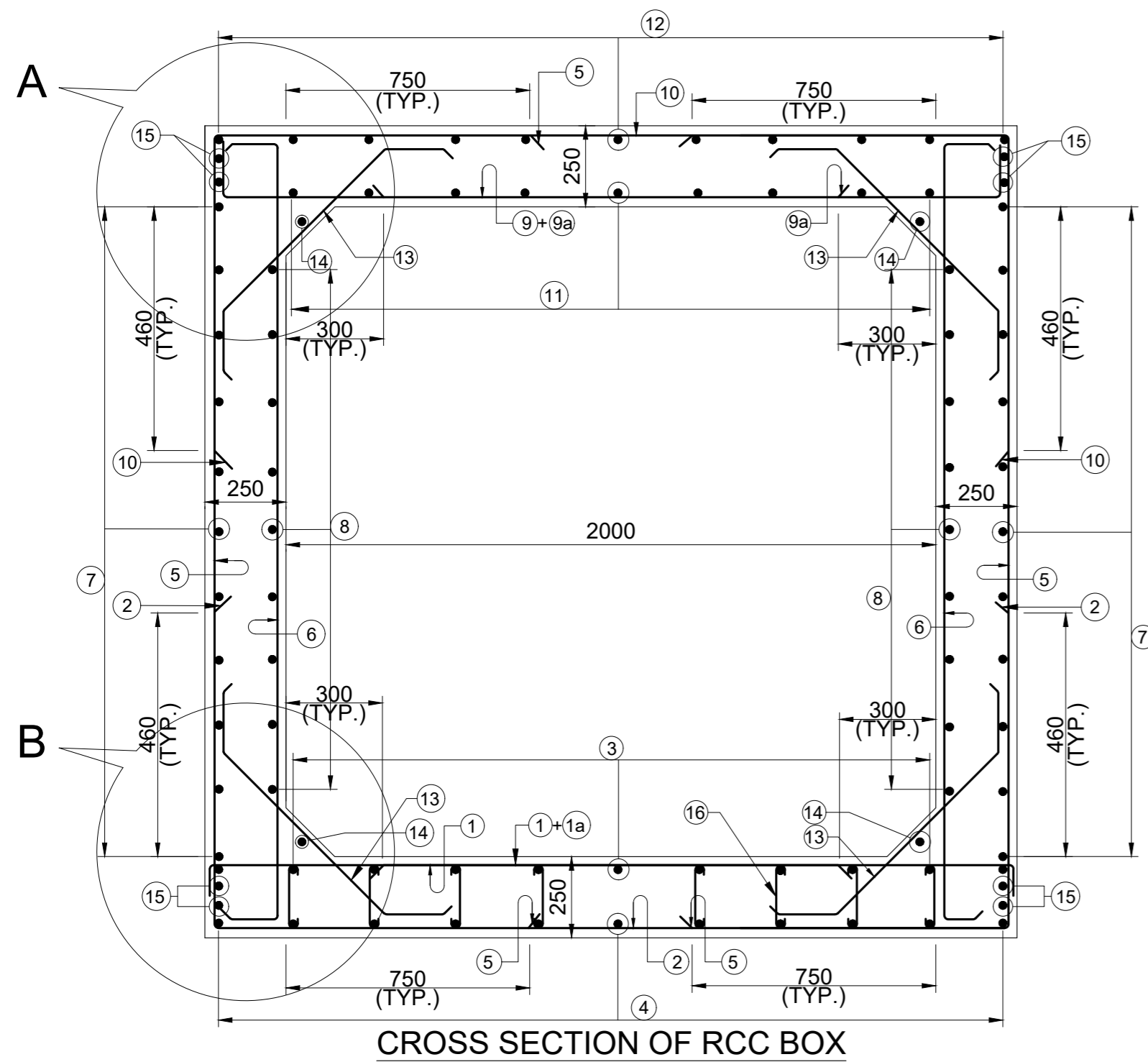

NOTE:-
 - - - - - TOP REINFORCEMENT
 _____ BOTTOM REINFORCEMENT

| REINFORCEMENT SCHEDULES | | | | |
|-------------------------|-----------|---------------|--|-----|
| BAR MARK | BAR SHAPE | BAR DIA IN mm | SPACING | NOS |
| 1 | | 12 | 200 | - |
| 1a | | 16 | 200 | - |
| 2 | | 12 | 200 | - |
| 3 | | 10 | 200 | - |
| 4 | | 10 | 200 | - |
| 5 | | 16 | 200 | - |
| 6 | | 10 | 200 | - |
| 7 | | 10 | 200 | - |
| 8 | | 10 | 200 | - |
| 9 | | 12 | 200 | - |
| 9a | | 12 | 200 | - |
| 10 | | 12 | 200 | - |
| 11 | | 10 | 200 | - |
| 12 | | 10 | 200 | - |
| 13 | | 10 | 200 | - |
| 14 | | 10 | - | 4 |
| 15 | | 10 | - | 8 |
| 16 | | 10 | Longitudinal 200C/C Transverse 200C/C | - |
| 17 | | 12 | 150 | - |
| 18 | | 10 | - | 4 |
| 19 | | 12 | 150 | - |
| 20 | | 12 | 150 | - |
| 21 | | 10 | - | 15 |
| 22 | | 16 | 150 | - |

- NOTES:-**
- ALL DIMENSIONS ARE IN MILLIMETERS AND LEVELS ARE IN METERS UNLESS OTHERWISE SPECIFIED.
 - DO NOT SCALE THE DRAWING FOLLOW FIGURED DIMENSIONS ONLY.
 - ALL DESIGN MIX CONCRETE SHALL CONFORM TO CL: 6.4 & CL: 18.5 OF IRC: 112-2011.
 - PRESSURE DEVELOPED AT THE BASE IS 12.5 T/m² IT SHALL BE ENSURED THAT THIS IS WITHIN THE SAFE BEARING CAPACITY OF THE STRATA.
 - CONDITION OF EXPOSURE : VERY SEVERE
 - SEISMIC ZONE - III
 - CLEAR COVER TO REINFORCEMENT :
RCC BOX & TROUGH : 75mm FOR ALL SOIL FACES
50mm FOR ALL OTHER THAN SOIL FACES
 - MINIMUM WEIGHT OF STONES USED FOR FLEXIBLE APRON SHOULD BE 40.0 KG.
 - THE BACK FILLING BEHIND BOX CULVERT WALL AND TROUGH WALL SHALL BE PROVIDED WITH SELECTED EARTH CONFIRMING TO APPENDIX 6 OF IRC: 78 - 2014 HAVING PROPERTIES OF $\phi \geq 30$ DEGREES AND C=0
 - 100 ϕ WEEP HOLES IN SLOPE 1:20 @ 1000 C/C STAGGERED BOTH HORIZONTALLY & VERTICALLY.
 - THE FILTER MATERIAL SHALL BE WELL PACKED TO A THICKNESS OF NOT LESS THAN 600mm WITH SMALLER SIZE TOWARDS THE SOIL AND BIGGER SIZE TOWARDS THE WALL AND PROVIDES OVER THE ENTIRE SURFACE BEHIND ABUTMENT RETURNS TO THE FULL HEIGHT (REFER APPENDIX - 6 OF IRC: 78 - 2014 FOR SPECIFICATIONS).
 - IN CASE OF FILLED UP SOIL / LOOSE POCKETS ENCOUNTERED AT FOUNDING LEVEL. THEN THE SAME SHALL BE REPLACED BY PROVIDING WELL GRADED NON PLASTIC COARSE MATERIAL COMPACTED TO 98% MDD TO ACHIEVE THE DESIGNED BASE PRESSURE. (THE BOTTOM OF REPLACED LAYER SHALL BE MINIMUM 0.9m IN TO NATURAL GROUND AS PER CL. 23.3 IRC: SP-13-2004).
 - IN CASE OF, THE PROPOSED FOUNDING LEVEL SHOWN IN THE DRAWING SAFE BEARING CAPACITY (SBC) OF SOIL IS LESS THAN DESIGNED BASE PRESSURE THEN THE SAME SHALL BE REPLACED BY PROVIDING WELL GRADED NON PLASTIC COARSE MATERIAL COMPACTED TO 98% MDD TO ACHIEVE THE DESIGNED BASE PRESSURE (THE BOTTOM OF REPLACED LAYER SHALL BE MINIMUM 0.9m IN TO NATURAL GROUND AS PER CL. 23.3 IRC: SP-13-2004).
 - THE JOINTS SHALL BE SEALED BY 3mm THICK ASPHALT, TO MAKE WATER TIGHT JOINT.

- SPECIFICATIONS:-**
- GRADE OF STEEL SHALL BE OF CRS - Fe500D OR ITS EQUIVALENT.
 - PROVIDE ANTI CORROSIVE TREATMENT TO STEEL REINFORCEMENT AS PER MORTH SPECIFICATIONS OR ELSE HIGH CORROSIVE RESISTANT MARINE BARS (HCRM) AS APPROVED BY THE ENGINEER-IN-CHARGE.
 - RCC BOX IN M40 (DESIGN MIX), USING 20mm ISS HBG GRADED METAL (FOR DETAILS REFER SEPERATE DRAWING).
 - PRECAST RCC CRASH BARRIER IN RCC M40 (DESIGN MIX) USING 20mm ISS HBG GRADED METAL.
 - PCC BELOW BOX & TROUGH IN PCC M15 (NOMINAL MIX) 100mm THICK, USING 40mm ISS HBG GRADED METAL.

| REV | DATE | DESCRIPTION | DSND | DWN | CHKD | APPD |
|-----|------------|---------------------|------|-----|------|------|
| R0 | 04-06-2020 | ISSUED FOR APPROVAL | | | | |

CLIENT :
TNRDC TAMILNADU ROAD DEVELOPMENT COMPANY LTD
Tamil Nadu Road Development Company Ltd

PROJECT:
 CONSTRUCTION OF ROAD ADJACENT TO IOCL (L&G) REGASIFICATION TERMINAL ROAD (INSIDE THE KPL)

DESIGN CONSULTANT :
VAX CONSULTANTS Pvt. Ltd
 Foundation & Structural Engineers

- GENERAL NOTES :**
- DO NOT SCALE THE DRAWING.
 - REFER DIMENSIONS ONLY.
 - ALL DIMENSIONS ARE IN M UNLESS OTHERWISE SPECIFIED.
 - CHAINAGES ARE IN "M"

| | |
|------------------|-----|
| JOB No. : | |
| DESIGNED | LMR |
| DRAWN | PVK |
| CHECKED | LMR |
| APPROVED | VVV |
| DATE | |

TITLE :
 REINFORCEMENT DRAWING FOR NEW & RECONSTRUCTION OF RCC BOX CULVERT

DRAWING NO :
 TNRDC-KPL/DPR/2020/STR/BC/1x2.0m/WD-01

SIZE: **SCALE :** **SHEET NO:** 03 OF 04

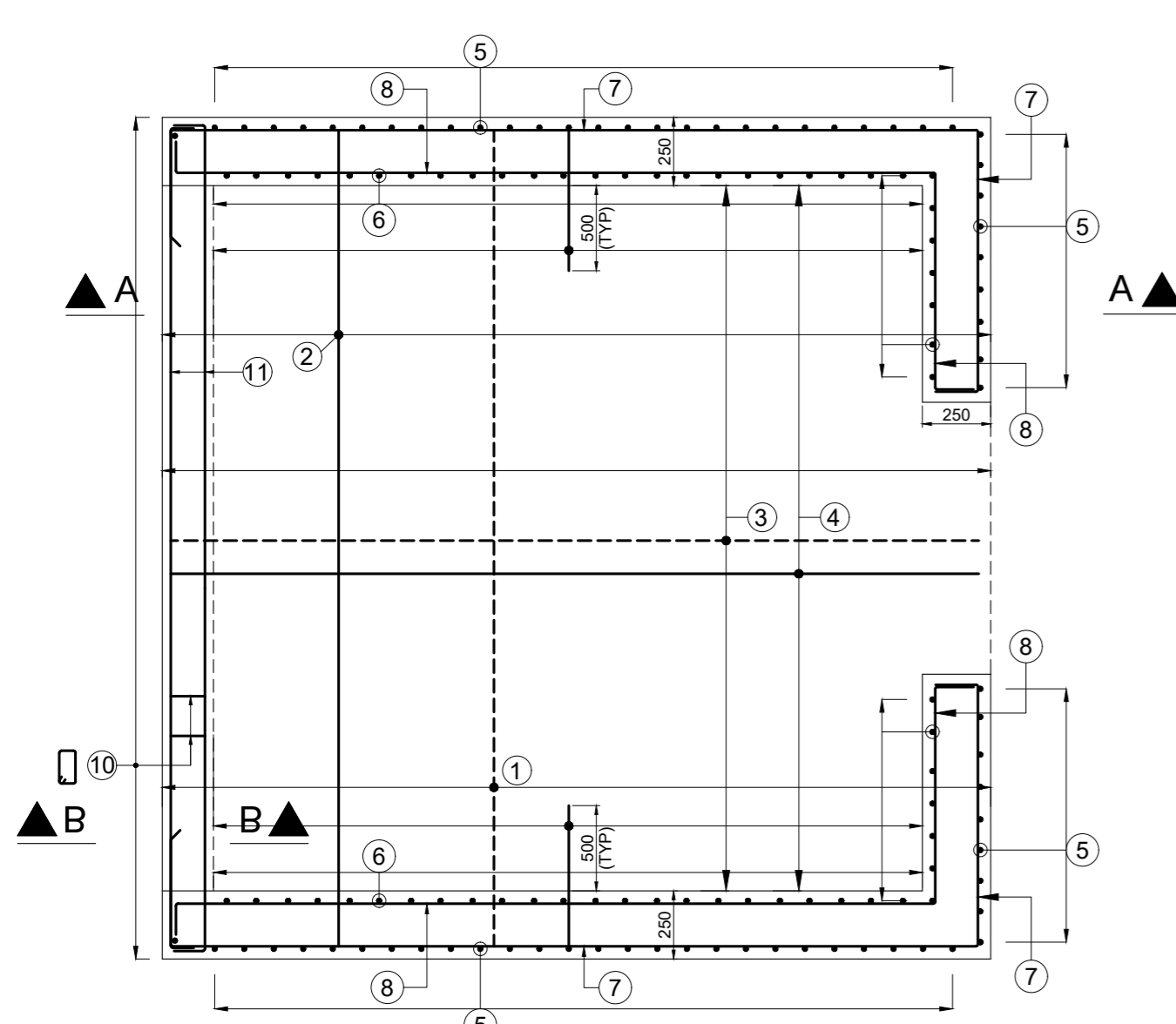

PLAN OF WING WALL

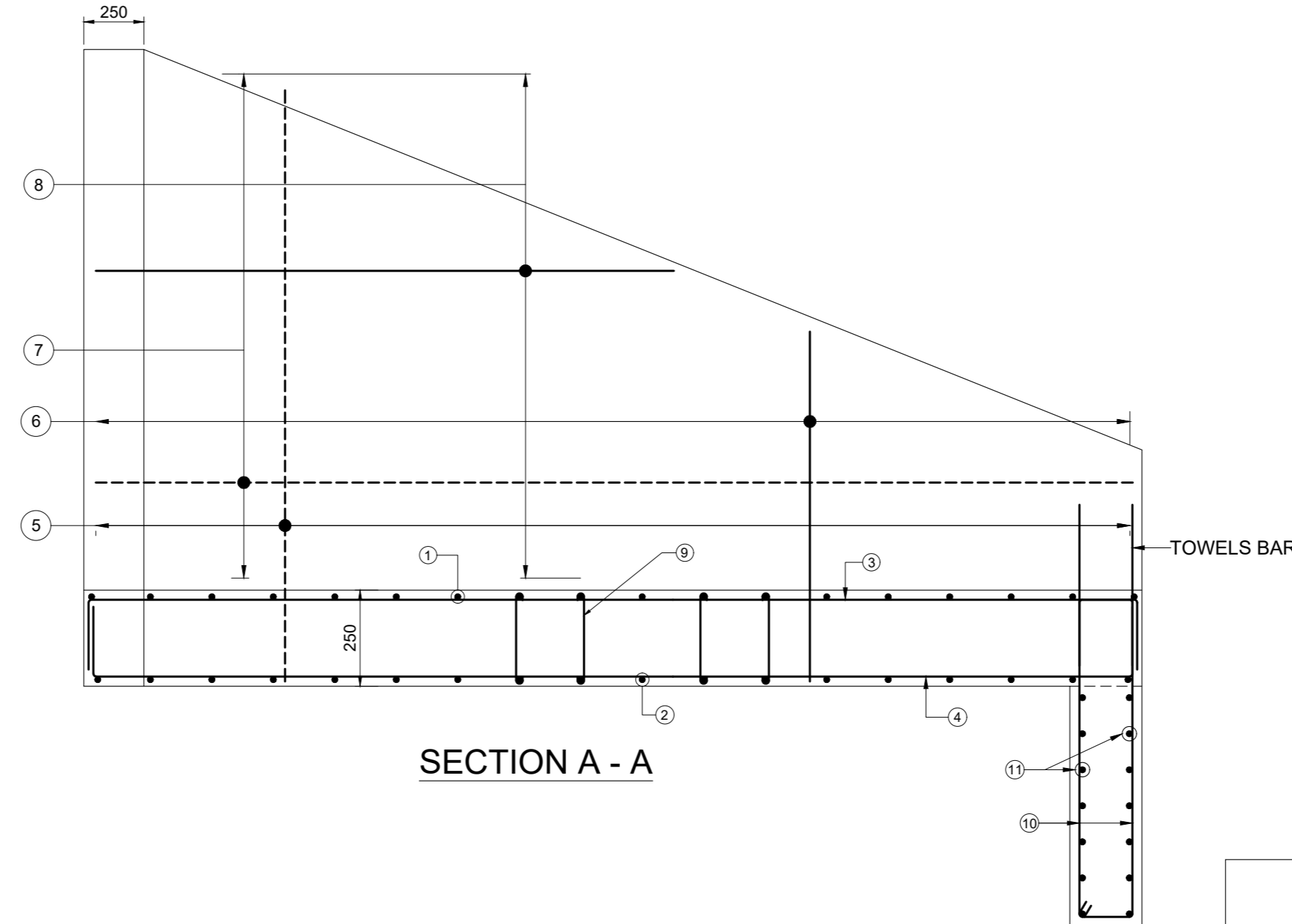

SECTION A - A

| REINFORCEMENT SCHEDULES | | | | |
|-------------------------|-----------|---------------|--|-----|
| BAR MARK | BAR SHAPE | BAR DIA IN mm | SPACING | NOS |
| 1 | | 12 | 200 | - |
| 2 | | 12 | 200 | - |
| 3 | | 10 | 200 | - |
| 4 | | 10 | 200 | - |
| 5 | | 16 | 200 | - |
| 6 | | 10 | 200 | - |
| 7 | | 10 | 200 | - |
| 8 | | 10 | 200 | - |
| 9 | | 10 | Longitudinal 400C/C Transverse 400C/C | - |
| 10 | | 12 | 150 | - |
| 11 | | 12 | 150 | - |

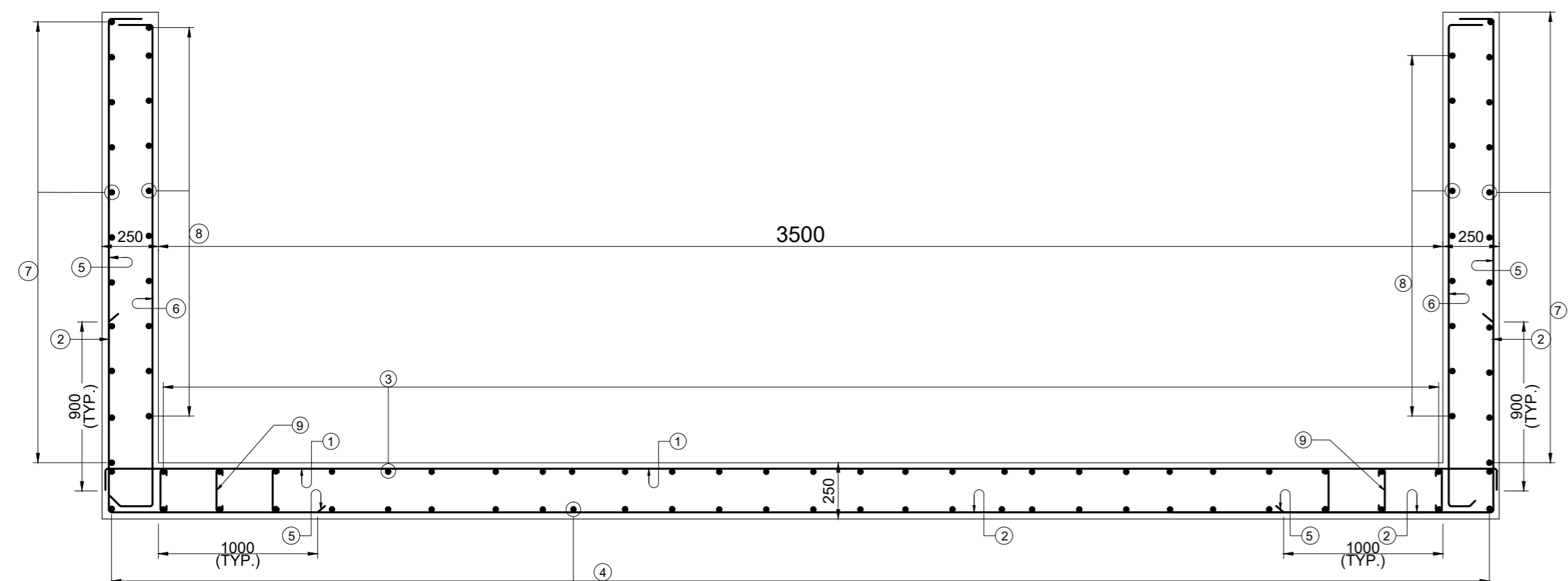

CROSS SECTION OF WING WALL

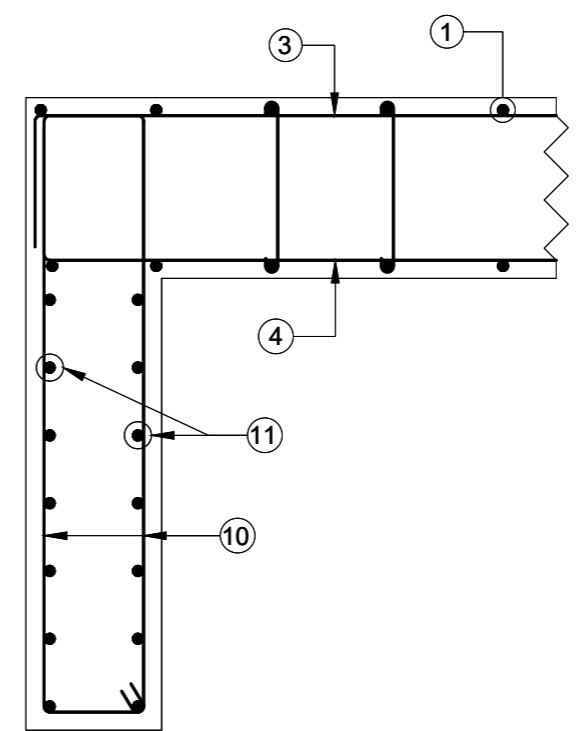

SECTION B - B

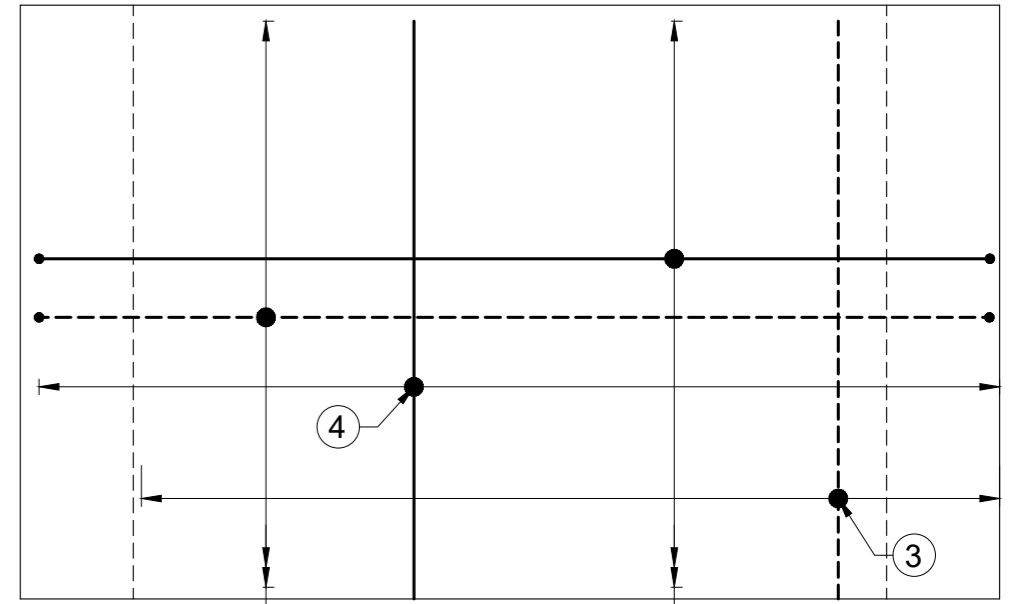

BOTTOM SLAB R/F PLAN
(WALL REINFORCEMENT & BOTTOM REINFORCEMENT NOT SHOWN)

--- TOP REINFORCEMENT
 ——— BOTTOM REINFORCEMENT

| | | | | | |
|-----|------------|---------------------|------|-----|------|
| RO | 04-06-2020 | ISSUED FOR APPROVAL | | | |
| REV | DATE | DESCRIPTION | DSND | DWN | CHKD |
| | | | | | APPD |

CLIENT :
TAMILNADU ROAD DEVELOPMENT COMPANY LTD
PROJECT:
CONSTRUCTION OF ROAD ADJACENT TO IOCL (L&G) REGASIFICATION TERMINAL ROAD (INSIDE THE KPL)

DESIGN CONSULTANT :
VAX CONSULTANTS PVT. LTD
 Foundation & Structural Engineers

GENERAL NOTES :
 1. DO NOT SCALE THE DRAWING.
 2. REFER DIMENSIONS ONLY.
 3. ALL DIMENSIONS ARE IN M UNLESS OTHERWISE SPECIFIED.
 4. CHAINAGES ARE IN "M"

JOB No. :
DESIGNED LMR
DRAWN PVK
CHECKED LMR
APPROVED VVV
DATE

TITLE :
 REINFORCEMENT DRAWING FOR NEW & RECONSTRUCTION OF RCC BOX CULVERT

DRAWING NO : TNRDC-KPL/DPR/2020/STR/BC/1x2.0m/WD-01
SIZE: **SCALE :** **SHEET NO:** 04 OF 04

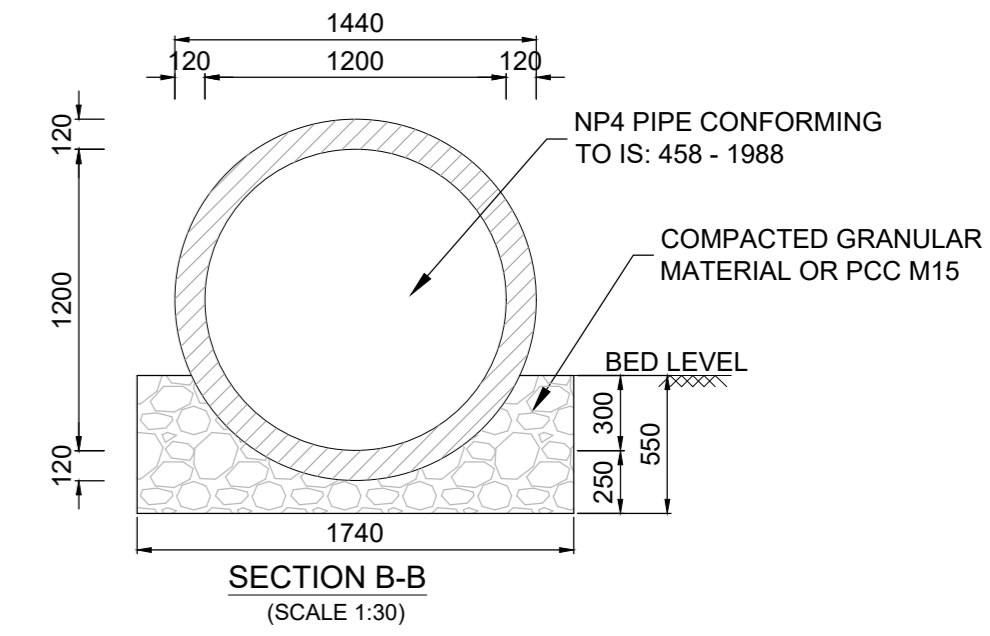
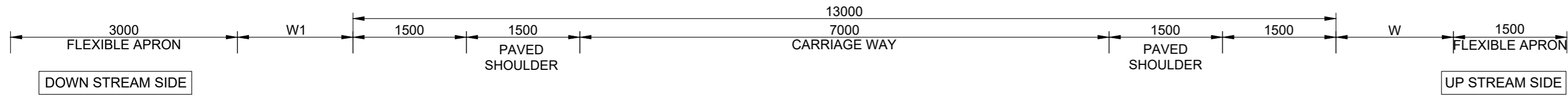
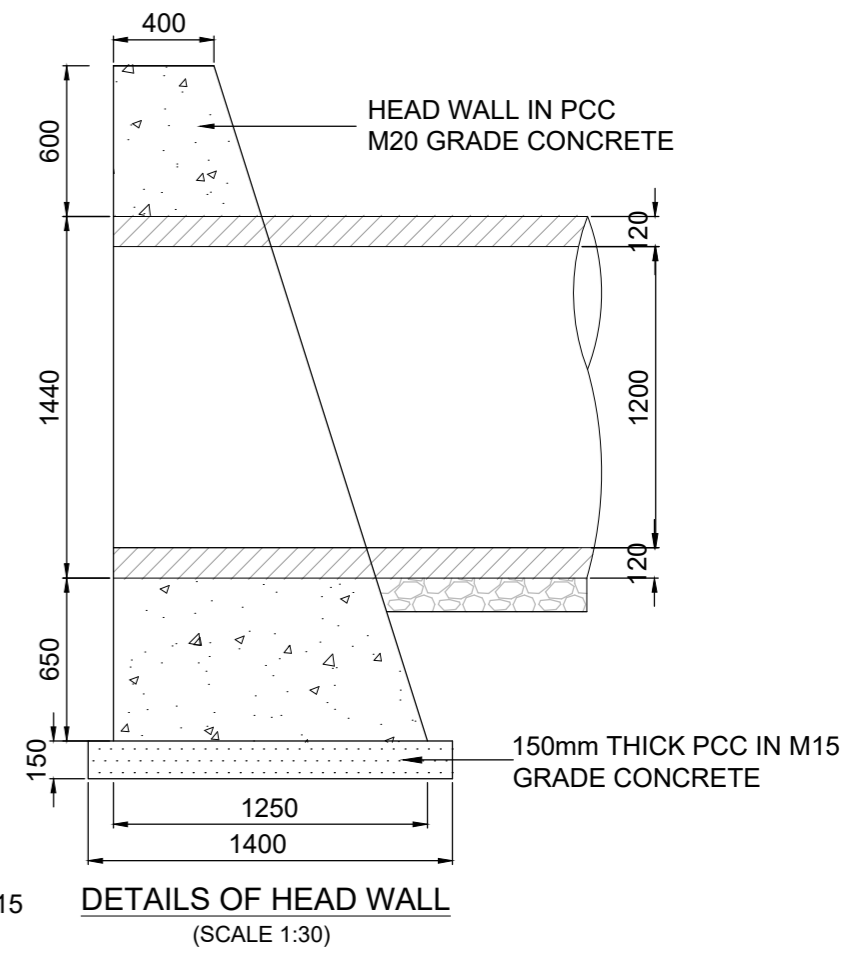
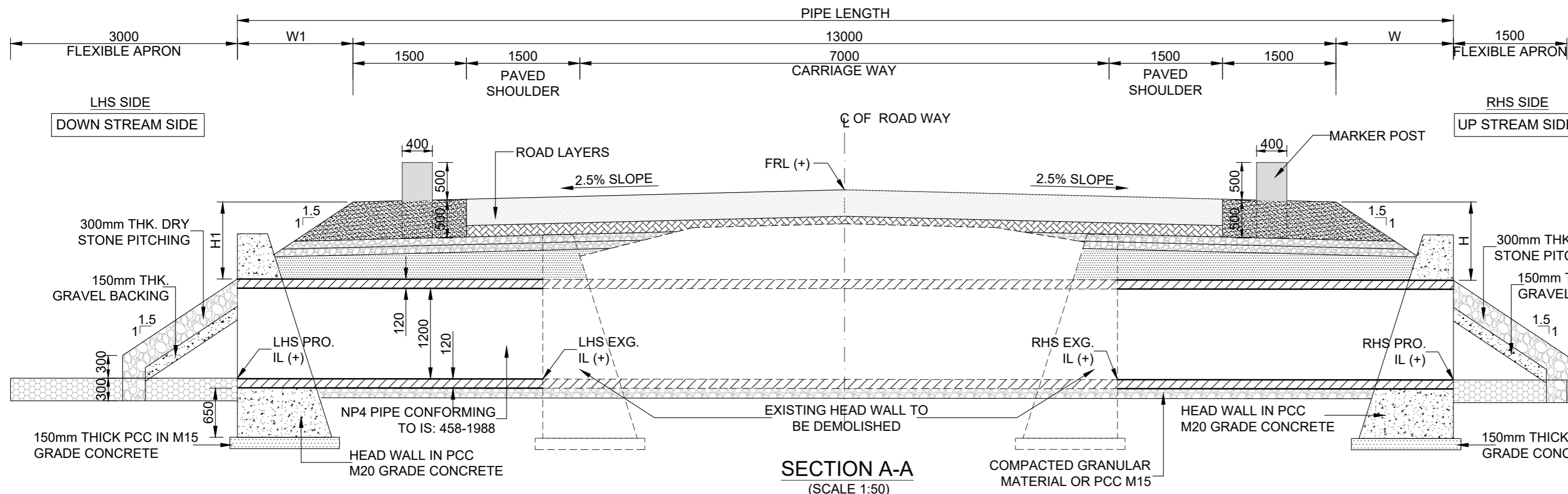

- NOTES:**
1. ALL DIMENSIONS ARE IN MILLIMETERS AND LEVELS IN METERS, UNLESS OTHERWISE MENTIONED.
 2. THE PIPES SHALL BE RCC NP4 NON PRESSURE PIPES, THE SPECIFICATIONS OF PIPES SHALL BE AS PER IS: 458 - 1988
 3. FIRST CLASS BEDDING CAN BE USED FOR MAXIMUM HEIGHT OF FILL OF 4 METERS
 4. PIPE SHALL BE JOINED BY INTERNAL FLUSH / SPIGOT & SOCKET JOINT AS PER IS 458
 5. LONGITUDINAL SLOPE OF PIPE CULVERT SHALL BE MINIMUM 1 IN 1000
 6. SLOPE OF THE EXISTING PIPE CULVERT SHOULD BE FOLLOWED FOR ALL WIDENING STRUCTURES AT SITE.
 7. MINIMUM HEIGHT TO FILL ABOVE THE PIPE SHOULD NOT BE LESS THAN 600mm. ENCASING OF PIPE SHALL BE DONE WHERE EVER CUSHION HEIGHT IS LESS THAN 600mm
 8. THE WORK SHALL BE EXECUTED AS PER IRC SP 13-2004 & MORTH SPECIFICATION.
 9. EXISTING PORTION OF PIPE, WHERE CONNECTION IS TO BE MADE WITH NEW PIPE, SHALL BE CLEANED THOROUGHLY.
 10. AFTER INSTALLATION OF PIPE, THE GAPS BETWEEN THE PIPES SHALL BE FILLED WITH CEMENT SAND MORTAR.
 11. TRENCHES SHALL BE KEPT FREE FROM WATER UNTIL THE PIPES ARE INSTALLED AND JOINTS HAVE HARDENED.
 12. INVERT LEVELS SHALL BE VERIFIED AT SITE, BEFORE START OF CONSTRUCTION.
 13. IF DURING EXCAVATION THE MATERIAL ENCOUNTERED IS SOFT, SPONGY OR OTHER UNSUITABLE TYPE, SUCH MATERIAL SHALL BE REMOVED AND BACKFILLED WITH APPROVED GRANULAR MATERIAL WHICH SHALL BE PROPERLY COMPACTED UP TO SPECIFIED LEVEL.

| Sl. No. | Design Chainage (km) | FRL RL (+) | | | Existing IL(+) | | Proposed IL(+) | | Camber in % | | Widening Length | | Length of Pipe | | W | W1 | H | H1 |
|---------|----------------------|------------|--------|-------|----------------|-------|----------------|-------|-------------|--------|-----------------|-------|----------------|-------|-------|-------|-------|-------|
| | | LHS | CENTRE | RHS | LHS | RHS | LHS | RHS | LHS | RHS | LHS | RHS | LHS | RHS | | | | |
| 1 | 1+649 | 4.337 | 4.499 | 4.337 | 1.993 | 2.228 | 1.991 | 2.231 | -2.50% | -2.50% | 2.510 | 2.895 | 4.046 | 4.079 | 1.184 | 1.536 | 0.789 | 1.024 |
| 2 | 2+155 | 4.407 | 4.569 | 4.407 | 2.330 | 2.559 | 2.326 | 2.561 | -2.50% | -2.50% | 3.560 | 2.340 | 4.696 | 3.132 | 0.792 | 1.136 | 0.528 | 0.757 |

| | | | | | | |
|-----|------------|---------------------|------|-----|------|------|
| REV | DATE | DESCRIPTION | DSND | DWN | CHKD | APPD |
| R0 | 04-06-2020 | ISSUED FOR APPROVAL | | | | |

CLIENT :
TAMILNADU ROAD DEVELOPMENT COMPANY LTD

PROJECT:
CONSTRUCTION OF ROAD ADJACENT TO IOCL (L&G) REGASIFICATION TERMINAL ROAD (INSIDE THE KPL)

DESIGN CONSULTANT :
VAX CONSULTANTS PVT. LTD
 Foundation & Structural Engineers

GENERAL NOTES :

1. DO NOT SCALE THE DRAWING.
2. REFER DIMENSIONS ONLY.
3. ALL DIMENSIONS ARE IN M UNLESS OTHERWISE SPECIFIED.
4. CHAINAGES ARE IN "M"

| | |
|------------------|-----|
| JOB No. : | |
| DESIGNED | LMR |
| DRAWN | PVK |
| CHECKED | LMR |
| APPROVED | VVV |
| DATE | |

TITLE :
 GENERAL ARRANGEMENT DRAWING FOR
 RETAINED & WIDENING OF PIPE CULVERT

DRAWING NO :
 TNRDC-KPL/DPR/2020/STR/PC/1x1.2m/WD-02

SIZE: **SCALE :** **SHEET NO:**

Section VII

Technical Specifications

SECTION-VII
Technical Specification

1.0 The Technical Specifications contained herein shall be read in conjunction with the other Bidding Documents.

1.1 Site Information

General

1.1.1 The information given hereunder and provided elsewhere in these documents is given in good faith by the Employer but the Contractor shall satisfy himself regarding all aspects of site conditions and no claim will be entertained on the plea that the information supplied by the Employer is erroneous or insufficient.

1.1.2 The area in which the works are located is in plain terrain, the approximate longitude and latitude of the region (Tamil Nadu) being 76° 15'/80° 20' East and 8° 05'/13° 35' North.

1.1.3 Climatic Conditions

1.1.3.1 The temperature in this region is as under:

i) During summer months, the average maximum temperature is 42°C.

ii) During winter months, the average minimum temperature is 18°C.

1.1.3.2 The average annual rainfall in the area is of the order of 800mm.

1.1.4 Seismic Zone

The works are located in Seismic Zone-II as defined in IS :1893 (Part I) - 2002

2 GENERAL REQUIREMENTS

The Technical Specifications in accordance with which the entire work described hereinafter shall be constructed and completed by the Contractor shall comprise of the following. All the specification given in the relevant codes, MoRTH shall be adhered to during execution of the work

2.1 Part-I: General Technical Specifications

The General Technical Specifications shall be the "SPECIFICATIONS FOR ROAD AND BRIDGE WORKS" (Fifth Revision), issued by the Ministry of Road Transport and Highways, Government of India and published by the Indian Roads Congress, henceforth called MORT&H Specifications and deemed to be bound into this document.

2.2 Part-II: Supplementary Technical Specifications

2.2.1 The Supplementary Technical Specifications shall comprise of various Amendments/Modifications/Additions to the "SPECIFICATIONS FOR ROAD AND BRIDGE WORKS" referred to in Part-I above and Additional Specifications for particular item of work not already covered in Part-I.

- 2.2.2 A particular clause or a part thereof in "SPECIFICATIONS FOR ROAD AND BRIDGE WORKS (Fifth Revision)" referred in Part-I above, where Amended/Modified/Added upon, and incorporated in Part-II, referred to above, such Amendment/Modification/ Addition supersedes the relevant Clause or part of the Clause.
- 2.2.3 The Additional Specifications shall comprise of specifications for particular item of works not already covered in Part-I.
- 2.2.4 When an Amended/Modified/Added Clause supersedes a Clause or part thereof in the said Specifications, then any reference to the superseded Clause shall be deemed to refer to the Amended/Modified/Added Clause or part thereof.
- 2.2.5 In so far as Amended/Modified /Added Clause may come in conflict or be inconsistent with any of the provisions of the said MORT&H Specifications under reference, the Amended/Modified/Added Clause shall always prevail.

2.2.6 **Additional Specifications**

In the absence of any definite provisions on any particular issue in the aforesaid Specifications, reference may be made to the latest codes and specifications of IRC, BIS, BS, ASTM, AASHTO and CAN/CSA in that order. Where even these are silent, the construction and completion of the works shall conform to sound engineering practice as approved by the Engineer and in case of any dispute arising out of the interpretation of the above, the decision of the Engineer shall be final and binding on the contractor.

The latest edition till 28 days before the final date of submission of the bid of all specifications / standard shall be applicable.